

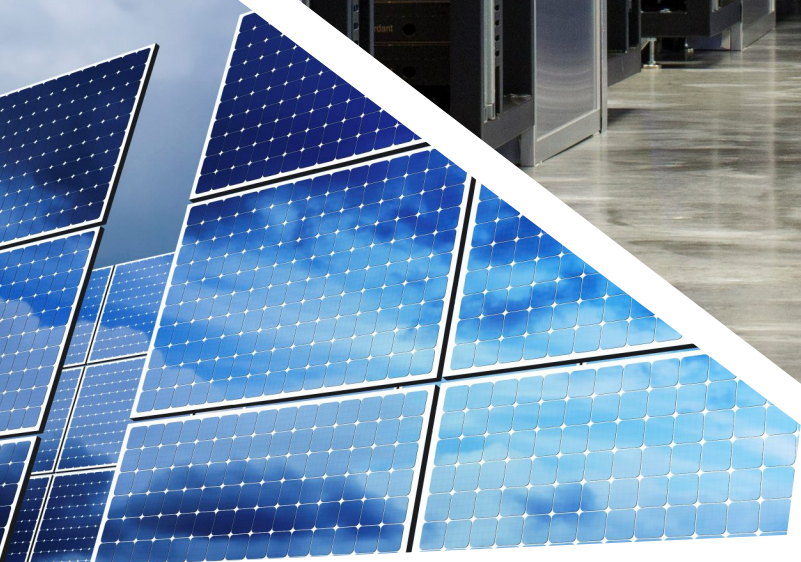

# *Catalogue*

*Quality Power Products*



# *Solar Power*

*Inverters, Solar Panels, Chargers*



***X*mart**  
***by Integra***



# *Catalogue*

## *Quality Power Products*

### Table of Contents

#### **1PH SOLAR INVERTERS**

XSI-B-120 1K/2K/3K  
XSI-B-230 1K/2K/3K/5K  
XSI-230-OGP 3K/5K

**1**

#### **2PH SOLAR INVERTERS**

XSI-2PLV 6K/10K

**2**

#### **3PH SOLAR INVERTERS**

XSI-3P-400 6/9/15K  
XSI-3PW-400 10/12/15/30K

**3**

#### **PORTABLE POWER STATIONS**

XSI-PPS 1.2K/2.5K  
XSI-PPS 3K  
XBAT-PPS-LFP 2.5KWh

**4**

#### **SOLAR CHARGERS**

XSI CHARGER MPPT 300/600  
XSI CHARGER MPPT 3K

**5**

#### **SOLAR PANELS**

POLY & MONO  
55W/80W/100W/  
120W/160W/200W/  
270W/320W/330W/  
545W

**6**

## Solar Inverter

# XSI-B-120V 1K/2K/3K

High efficiency Solar inverter with pure sine-wave output for 120Vac systems. Thanks to their robust and modern design, XSI Inverters can operate in electrically and environmentally hostiles sites. Counts on 2 powerful chargers, one powered by solar input and another powered by AC Input. Avant-garde technology allows to be simultaneously powered by AC Input and Solar Input. Priority of usage for these two inputs can be configured by the user. Includes several communication possibilities and control software.

### Features

- ▣ Design based on microprocessors and DSP
- ▣ 120Vac Pure sine-wave output
- ▣ High efficiency conversion
- ▣ Parallel installation up to 6 units (3K models)
- ▣ Smart internal chargers: Solar and AC
- ▣ Configurable priority of usage for multiple inputs:
  - Solar Panels
  - AC Line (Grid)
  - Batteries
- ▣ Fully compatible with Power Generators
- ▣ Multiple communication ports and control software
- ▣ Cold Start and y Auto Restart
- ▣ Compatible with all kind of solar panels
- ▣ Supports LiFePO4 Batteries



### Operation with multiple power supplies

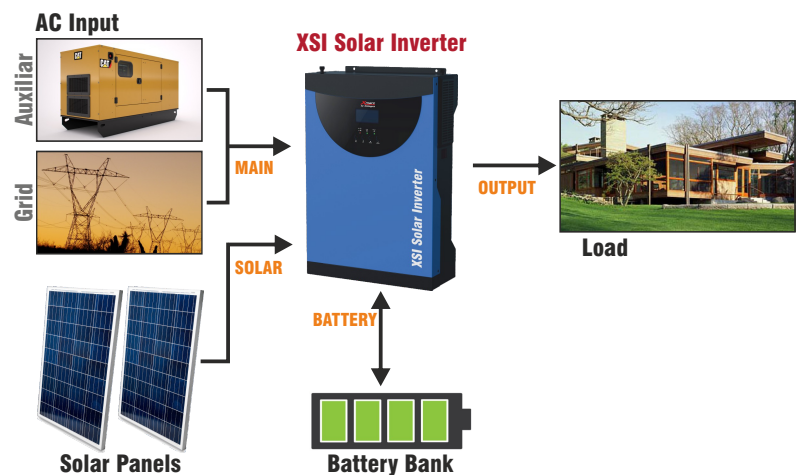

# Solar Inverter

# XSI-B-120V 1K/2K/3K

## Features

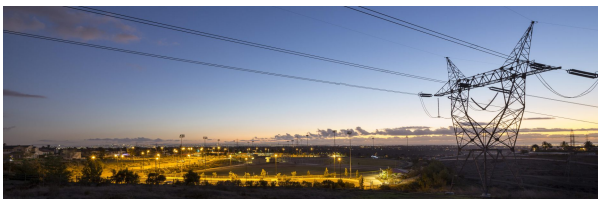

### Solar Input

#### Wide Range of Operation

A wide range of voltage on Solar Input helps to charge batteries efficiently and keeps an optimum AC output even during big voltage variation from solar panels.

1K: 15 - 80 V  
2K: 30 - 115 V  
3K: 30 - 115 V

#### High VOC (Solar Panel Open Circuit Voltage)

High value in VOC allows working with a larger solar panel array with serial connection, easing the installation and achieving higher levels of solar power, with lower current.

1K: 102 VDC  
2K: 145 VDC  
3K: 145 VDC

### AC Input

#### Selectable Operation Range

AC Input range can be configured in 2 different modes; Wide (65-140V) and PC (90-140V).

#### Compatible with Power Generators

XSI-B inverters can filter voltage fluctuation from Power Generators to generate clean and pure sine-wave power for your equipment

### 3 Stages internal Smart Battery Chargers

#### MPPT Solar Charger

This Inverter series includes MPPT (max. power point tracking) Technology Solar Charger to optimize the batteries charging capacity even during big changes of solar input.

1K: 40 A  
2K: 60 A  
3K: 80 A

#### AC Charger

AC Charger is powered by input AC. A high adjustable charging current offers, fulfil the needs of your battery bank.

1K: 10/20A  
2K: 20/30A  
3K: 10-60A

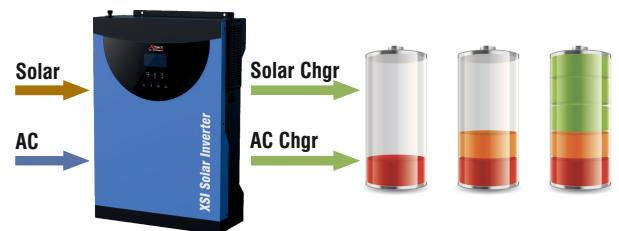

### Communication and Software

#### Multiple Communication Channels

This inverter family includes USB and RS-232 communication ports, as well as dry contact interface. Moreover, there are additional options: LAN-Ethernet, and Modbus.

#### Software

Xsmart software, specific for XSI inverters, is available for most Operating Systems: Windows, Linux (32&64) y MAC 64 bits. Our software allows consulting the inverter status, power sources, load; as well as configuring all adjustable parameters, and recording data, alarms and, system events.

### Additional Features

#### Parallel Operation

3K models support parallel installation for capacity enlargement, up to 6 units, so total capacity can be increased up to 18 KW, using 3KW units.

## Technical Specifications

XSI-B - SOLAR INVERTER 120V - (1/2)	1K-12-MPP	2K-24-MPP	3K-24-MPP
Out Capacity / Capacidad de Salida (VA)	1000 VA	2000 VA	3000 VA
Output Capacity / Capacidad de Salida (W)	800 W	1600 W	2400 W
<b>MAIN FEATURES / FUNCIONALIDADES</b>			
Parallel / Operación paralela	x		6 units max Optional / Opcional
Built-in Charger / Cargador incorporado	MPPT		
AC-Solar Priority / Prioridad Solar-CA	Configurable by LCD - Display		
Parameters setting / Configuración de parámetros	by LCD - Display		
Auto-Restart / Rearmado automático	✓		
Remote LCD / Panel LCD remoto	✓		
Mounting / Montaje	Wall mounting / En pared		
<b>AC INPUT / ENTRADA CA</b>			
Voltage / Tensión	110 VAC / 120 VAC		
Input Range / Rango de entrada	Selectable / Seleccionable: Wide Range Mode: (65-140VAC) / PC Mode: (95-140VAC)		
Freq. Range / Rango Frecuencia	50Hz / 60Hz Auto sensing - (40Hz - 65Hz)		
Generator AC / Motogenerador C.A.	Compatible		
Phase / Fases	1 phase / 1 fase: 120Vac (L-N)		
<b>OUTPUT / SALIDA</b>			
Voltage Output / Voltaje de Salida AC	Selectable: 110VAC / 120VAC		
Output Regulation / Regulación de Salida	+/- 5% (battery mode / modo batería)		
Transfer Time / Tiempo AC a Inversor	10ms (PC mode) / 20ms (Wide range mode)		
Waveform / Forma de Onda	Pure Sinewave / Sinusoidal Pura		
Output Current / Corriente de Salida	9 A MAX.	18 A MAX.	26 A MAX.
<b>EFFICIENCY / EFICIENCIA</b>			
Line mode Efficiency / Eficiencia modo línea	>95%		
Inverter Efficiency / Eficiencia del inversor	>90%	>93%	>90%
No load consumption / Consumo interno sin carga	<15W	<25W	<25W
Saving mode consumption / Consumo modo saving	<5W	<10W	<10W
Standby consumption / Consumo en standby	<2W		
<b>OVERLOAD/ SOBRECARGA</b>			
Overload protection / Protección alto consumo	(<110%: OK) / (110% to 150%: 10s) / (>150%: 5s)		
Surge Power / Potencia Máxima	2000 VA (5s)	4000 VA (5s)	6000 VA (5s)
<b>PROTECTIONS</b>			
Short circuit Protection / Protección cortos	Line mode: Breaker / Battery mode: Electronic protection		
Input Current / Corriente de Entrada	Circuit Breaker / Disyuntor		
<b>BATTERIES / BATERIAS</b>			
Type / Tipo	Sealed Lead Acid / Sellada de Libre Mantenimiento: VRLA, AGM, GEL & LiFePO4		
Rated Voltage / Tensión DC nominal	12 VDC	24 VDC	
Low DC warning / Aviso batería baja (Load >50%)	10.1VDC	20.2VDC	
Low DC shutdown / Apagado por batería baja (load>50%)	9.6 VDC	19.2 VDC	
(20%>load>50%)	10.2 VDC	20.4 VDC	
(load<20%)	10.5 VDC	21.0 VDC	
Cold start / Arranque en frío	> 11.5 VDC	> 23.0VDC	
Battery Current / Corriente de baterías	80 A MAX.		150 A MAX.
<b>USER INTERFACE / INTERFAZ CON EL USUARIO</b>			
LCD & 3 LED	AC & PV Inputs (V), Output (V), Load (%), Batt. level, Charging status (%), Op. mode, etc Entrada AC y Solar (Voltios), Salida (V), Consumo, Batería, Cargador, Modo de op., etc		
<b>ALARM / ALARMAS</b>			
Alarm Beep / Alarma Sonora:	Beep alarm is activated to warn about alarms / Alarma sonora para alarmas		
Alarm Codes / Mensajes de Alarma	Alarm & fault codes are displayed on LCD / Mensajes de alarma y error en pantalla		

## Technical Specifications

XSI-B - SOLAR INVERTER 120V - (2/2)	1K-12-MPP	2K-24-MPP	3K-24-MPP
<b>CHARGERS (SOLAR &amp; AC)</b>			
Solar charger type / Cargador solar	MPPT		
Charging procedure / Tipo de recarga	3 steps: 1-Constant Current (Bulk), 2-Constant Voltage, 3-Floating		
Data for VRLA Batteries / Datos para Baterías VRLA			
Bulk Charging / Voltaje cargador (Etapa Bulk)	14.1 VDC	28.2 VDC	
Floating Charging / Voltaje cargador (Etapa Floating)	13.5 VDC	27 VDC	
Overcharge Protection / Protección Sobrecarga	15.5 VDC	33 VDC	
Max. PV Power / Potencia Max. Entrada PV	500 W	1500 W	2000 W
Max. PV VOC / Voltaje en abierto paneles (VOC)	102 VDC	145 VDC	
PV Array MPPT Range / Rango MPPT	15 - 80 VDC	30 - 115 VDC	
Solar charger Amps / Corriente cargador solar	40 A MAX.	60 A MAX.	80A MAX.
AC charger Amps / Corriente cargador CA	10/20A	20/30 A	10/20/30/40/50/60A
Total charging Amps / Total corriente cargador	60 A MAX.	90 A MAX.	140 A MAX.
Efficiency / Eficiencia	98% MAX		
<b>CONNECTIONS / CONEXIONES</b>			
AC Main / Entrada CA (L-N-G)	Hard wired / Regleta		
AC Output / Salida CA (L-N-G)	Hard wired / Regleta		
Battery Input / Entrada de Baterías (+) & (-)	Hard wired / Regleta		
Solar Panel Input / Entrada Panel Solar (+) & (-)	Hard wired / Regleta		
<b>SAFETY / SEGURIDAD</b>			
Safety certifications / Certificados de Seguridad	CE		
<b>PHYSICAL / FISICAS: UPS</b>			
DxWxH / Prof.*Ancho*Altura (mm)	100 x 272 x 355	140 x 295 x 479	125 x 300 x 440
Net Weight / Peso Neto (kgs)	6,8	11,5	11
<b>OPERATIONAL CONDITIONS / CONDICIONES DE OPERACIÓN</b>			
Installation Site / Lugar Instalación	IP20 (Indoor / Ambiente Interior)		
Rel. Humidity / Humedad Relativa	< 95 % RH (non-condensing / no condensante)		
Operating Temperature / Temperatura Operación	0 to 55 °C		
Storage Temperature / Temperatura Almacenaje	-15 to 60 °C		
Max. Altitude / Altura de Operación Max.	4.500 meters over sea level / sobre nivel del mar. * Power output de-rate of 1% every 100m (over 1.500m) * Disminución de potencia de 1% cada 100m (sobre los 1.500m)		
<b>COMMUNICATION / COMUNICACION</b>			
USB	Built-in (incorporado)		
RS232	Optional (Opcional)	Built-in (incorporado)	
Dry Contacts / Contactos secos	Built-in (incorporado)		
SNMP (LAN Ethernet)	Optional (Opcional)		
Modbus RS485	Optional (Opcional)		
Software	Available for Windows family, Linux 32 & 64bits, MAC 64bits. Main functions: Monitor multiple inverters, data and event logs, alarm messages and remote configuration. Para Windows, Linux 32 & 64bits, MAC 64bis. Funciones principales: Supervisión de múltiples inversores, registro de datos y eventos, mensajes de alarma y config. remota.		

Technical specifications can be modified to comply with special requirements / Las especificaciones pueden, bajo requerimiento, adaptarse a proyectos  
 Technical specifications may change without further notice / Por motivos comerciales o técnicos las especificaciones pueden cambiar sin previo aviso.

This inverter family requires battery connection to operate. See details in chapter 5 in User Manual.

Esta familia de inversores requiere conexión a las baterías para operar en cualquier condición. Ver detalles en la sección 5 del Manual de Usuario.

## Solar Inverter

# XSI-B-230V-MPP 1K/2K/3K/5K

High efficiency Solar inverter with pure sine-wave output for 220/230Vac systems. Thanks to their robust and modern design, XSI inverters can operate in electrically and environmentally hostile sites. Counts on 2 powerful chargers, one MPPT powered by Solar Input and another powered by AC Input. Avant-garde technology allows to be simultaneously fed by AC Input and Solar Input. Priority of usage for these two inputs can be configured by the user. Includes several communication possibilities and control software.

### Features

- Design based on microprocessors and DSP
- Pure sine-wave output
- High efficiency conversion
- Parallel installation up to 9 units (5K model)
- Smart internal chargers: Solar (MPPT) and AC
- Compatible with MPPT external chargers
- Configurable priority of usage for multiple inputs:
  - Solar Panels
  - AC Line (Grid)
  - Batteries
- Fully compatible with Power Generators
- Remote LCD Panel (optional, 5K Model)
- Dust filtering kit (optional)
- Multiple communication ports and control software
- Cold Start and y Auto Restart
- Compatible with all kind of solar panels
- Supports LiFePO4 batteries



### Operation with different power supplies

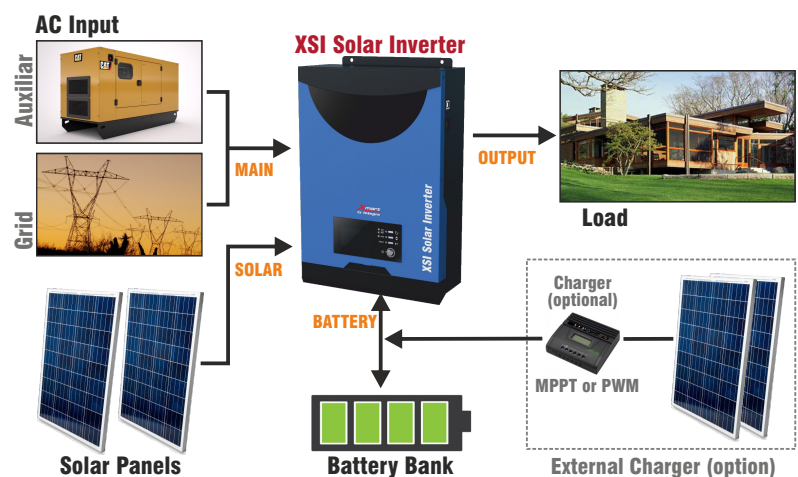

# Solar Inverter

# XSI-B-230V-MPP 1K/2K/3K/5K

## Features

### Solar Input

#### Wide Range of Operation

A wide range of voltage on Solar Input helps to charge batteries efficiently and keeps an optimum AC output even during big voltage variation from solar panels.

1K: 15 - 80V  
2K/3K: 30 - 80V  
5K: 60 - 115V

#### High VOC (Solar Panel Open Circuit Voltage)

High value in VOC allows working with a larger solar panel array with serial connection, easing the installation and achieving higher levels of solar power, with lower current.

1K: 102VDC  
2K/3K: 102VDC  
5K: 145VDC



### AC Input

#### Selectable Operation Range

AC Input range can be configured in 2 different modes; Wide (90-280V) and PC (170-280V).

#### Compatible with Power Generators

XSI inverters can filter voltage fluctuation from Power Generators to generate clean and pure sine-wave power for your equipment



### 3 Stages internal Smart Battery Chargers

#### MPPT Solar Charger

This Inverter series includes MPPT (max. power point tracking) Technology Solar Charger to optimize the batteries charging capacity even during big changes of solar input.

1K/2K: 40A MAX  
3K: 40A MAX  
5K: 80A MAX

#### AC Charger

AC Charger is powered by input AC. A high adjustable charging current offers, fulfil the needs of your battery bank.

1K/2K: 20A MAX  
3K: 25A MAX  
5K: 60A MAX

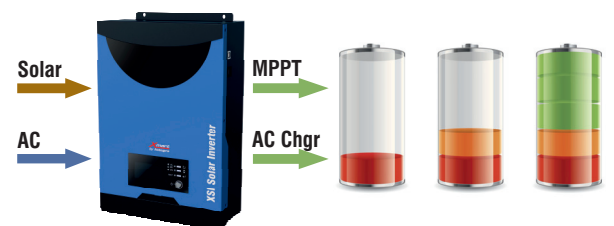

### Communication and Software

#### Multiple Communication Channels

This inverter family includes USB and RS-232 communication ports, as well as dry contact interface. Moreover, there are additional options: LAN-Ethernet, and Modbus.

#### Software

Xmart software, specific for XSI inverters, is available for most Operating Systems: Windows, Linux (32&64) y MAC 64 bits. Our software allows consulting the inverter status, power sources, load; as well as configuring all adjustable parameters, and recording data, alarms and, system events.

### Additional Features

#### Parallel Operation

5K model supports parallel installation for capacity enlargement, up to 9 units, so total capacity can be increased up to 45 KW.

#### Remote Operation Panel

LCD panel for 5K Inverter can be removed and installed for remote operation. Remote panel can be installed up to 5 meters away from the inverter and it is hard wired.

## Technical Specifications

XSI-B - SOLAR INVERTER 230V - MPP (1/2)	1K-12-MPP	2K-24-MPP	3K-24-MPP
Out Capacity / Capacidad de Salida (VA)	1000 VA	2000 VA	3000 VA
Output Capacity / Capacidad de Salida (W)	1000 W	2000 W	3000 W
<b>MAIN FEATURES / FUNCIONALIDADES</b>			
Parallel / Operación paralela	x		
Built-in Charger / Cargador incorporado	MPPT		
AC-Solar Priority / Prioridad Solar-CA	Configurable by LCD - Display		
Parameters setting / Configuración de parámetros	by LCD - Display		
Auto-Restart / Rearmado automático	✓		
Anti-dust kit / Kit filtro anti polvo	✓		
Remote LCD / Panel LCD remoto	x		
Mounting / Montaje	Wall mounting / En pared		
<b>AC INPUT / ENTRADA CA</b>			
Voltage / Tensión	230 VAC		
Input Range / Rango de entrada	Selectable / Seleccionable: Wide Range Mode: (90-280VAC) / PC Mode: (170-280VAC)		
Input frequency / Frecuencia de entrada	50Hz / 60Hz Auto sensing - (40Hz - 65Hz)		
AC Generator / Motogenerador C.A.	AC input compatible with generator / Entrada compatible con moto-generadores		
Phase / Fases	1 phase / 1 fase: 220/230 VAC (L-N)		
<b>OUTPUT / SALIDA</b>			
Voltage Output / Voltaje de Salida AC	230VAC		
Output Regulation / Regulación de Salida	+/- 5% (battery mode / modo batería)		
Transfer Time / Tiempo AC a Inversor	10ms (PC mode) / 20ms (Wide range mode)		
Waveform / Forma de Onda	Pure Sinewave / Sinusoidal Pura		
Output Current / Corriente de Salida	4.5 A MAX.	9 A MAX.	13.5 A MAX.
<b>EFFICIENCY / EFICIENCIA</b>			
Inverter Efficiency / Eficiencia del inversor	93%		
Line mode Efficiency / Eficiencia modo línea	>95%		
No load consumption / Consumo interno sin carga	<25W		
Saving mode consumption / Consumo modo saving	<10W		
Standby consumption / Consumo en standby	<2W		
<b>OVERLOAD/ SOBRECARGA</b>			
Overload protection / Protección alto consumo	(<105%: OK) / (105% to 150%: 10s) / (>150%: 5s)		
Surge Power / Potencia Máxima	2.000 W (5s)	4.000 W (5s)	6.000 W (5s)
<b>PROTECTIONS</b>			
Short circuit Protection / Protección cortos	Line mode: Breaker / Battery mode: Electronic protection		
Input Current / Corriente de Entrada	Circuit Breaker / Disyuntor		
<b>BATTERIES / BATERIAS</b>			
Type / Tipo	Sealed Lead Acid / Sellada de Libre Mantenimiento: VRLA, AGM, GEL & LiFePO4		
Rated Voltage / Tensión DC nominal (VDC)	12	24	
Low DC warning / Aviso batería baja (VDC)	Load>50%: 11	Load>50%: 22	
Low DC shutdown / Apagado por batería baja			
Load>50% (VDC)	10.5	21.0	
Load<50% (VDC)	10.7	21.4	
Cold start / Arranque en frío	> 11.5 VDC	> 23.0VDC	
Battery Current / Corriente de baterías	100 A MAX.	100 A MAX.	150 A MAX.
<b>USER INTERFACE / INTERFAZ CON EL USUARIO</b>			
LCD & LED	AC&PV Inputs, Output, Load (%), Battery level, Charging status (%), Operation mode, etc Valores de entrada AC y Solar, Salida, Consumo, Batería, Cargador, Modo de operación, etc		
<b>ALARM / ALARMAS</b>			
Alarm Beep / Alarma Sonora	Beep alarm is activated to warn about alarms / Alarma sonora para anunciar alarmas		
Alarm Codes / Mensajes de Alarma	Alarm & fault codes are displayed on LCD / Mensajes de alarma y error mostrados en el LCD		

## Technical Specifications

XSI-B - SOLAR INVERTER 230V - MPP (2/2)	1K-12-MPP	2K-24-MPP	3K-24-MPP
<b>CHARGERS (SOLAR &amp; AC)</b>			
Solar charger type / Cargador solar	MPPT		
Charging procedure / Tipo de recarga	3 steps: 1-Constant Current (Bulk), 2-Constant Voltage, 3-Floating		
Data for VRLA Batteries / Datos para Baterías VRLA			
Bulk Charging / Voltaje cargador (Etapa Bulk)	14.1 VDC	28.2 VDC	
Floating Charging / Voltaje cargador (Etapa Floating)	13.5 VDC	27 VDC	
Overcharge Protection / Protección Sobrecarga	15.5 VDC	31 VDC	33 VDC
Max. PV Power / Potencia Max. Entrada PV	500 W	1000 W	
Max. PV VOC / Voltaje en abierto paneles (VOC)	102 VDC	102 VDC	
PV Array MPPT Range / Rango MPPT	15 to 80 VDC	30 to 80 VDC	
Solar charger Amps / Corriente cargador solar	40 A MAX.	40 A MAX.	
AC charger Amps / Corriente cargador CA	20 A MAX.	20 A MAX.	25 A MAX.
Total charging Amps / Total corriente cargador	60 A MAX.	60 A MAX.	
Efficiency / Eficiencia	98% MAX		
<b>CONNECTIONS / CONEXIONES</b>			
AC Main / Entrada CA (L-N-G)	Hard wired / Regleta		
AC Output / Salida CA (L-N-G)	Hard wired / Regleta		
Battery Input / Entrada de Baterías (+) & (-)	Hard wired / Regleta		
Solar Panel Input / Entrada Panel Solar (+) & (-)	Hard wired / Regleta		
<b>SAFETY / SEGURIDAD</b>			
Safety certifications / Certificados de Seguridad	CE		
<b>PHYSICAL / FISICAS: UPS</b>			
DxWxH / Prof.*Ancho*Altura (mm)	88 x 225 x 320	88 x 225 x 320	100 x 285 x 334
Net Weight / Peso Neto (kgs)	5	5,5	6,3
<b>OPERATIONAL CONDITIONS / CONDICIONES DE OPERACIÓN</b>			
Installation Site / Lugar Instalación	IP20 (Indoor / Ambiente Interior)		
Rel. Humidity / Humedad Relativa	< 95 % RH (non-condensing / no condensante)		
Operating Temperature / Temperatura Operación	-10 to 55 °C		
Storage Temperature / Temperatura Almacenaje	-15 to 60 °C		
Max. Altitude / Altura de Operación Max.	4.500 meters over sea level / sobre nivel del mar. * Power output derate of 1% every 100m (over 1.500m) * Disminución de potencia de 1% cada 100m (sobre los 1.500m)		
<b>COMMUNICATION / COMUNICACION</b>			
USB	Built-in (incorporado)		
RS232	Built-in (incorporado)		
Dry Contacts / Contactos secos	x		
SNMP (LAN Ethernet)	Optional (Opcional)		
Modbus RS485	Optional (Opcional)		
Software	Available for Windows family, Linux 32 & 64bits, MAC 64bits. Main functions: Monitor multiple inverters, data and event logs, alarm messages and remote configuration for inverters Para Windows, Linux 32 & 64bits, MAC 64bis. Funciones principales: Supervisión de múltiples inversores, registro de datos y eventos, mensajes de alarma y config. remota.		

Technical specifications can be modified to comply with special requirements / Las especificaciones pueden, bajo requerimiento, adaptarse a proyectos especiales

Technical specifications may change without further notice / Por motivos comerciales o técnicos las especificaciones pueden cambiar sin previo aviso.

This inverter family requires battery connection to operate. See details in chapter 5 in User Manual.

Esta familia de inversores requiere conexión a las baterías para operar en cualquier condición. Ver detalles en la sección 5 del Manual de Usuario.

## Technical Specifications

### XSI-B - SOLAR INVERTER 230V - MPP (1/2)

### 5KP-48-MPP

Out Capacity / Capacidad de Salida (VA)	5000 VA
Output Capacity / Capacidad de Salida (W)	5000 W
<b>MAIN FEATURES / FUNCIONALIDADES</b>	
Parallel / Operación paralela	9 units max Optional / Opcional
Built-in Charger / Cargador incorporado	MPPT
AC-Solar Priority / Prioridad Solar-CA	Configurable by LCD - Display
Parameters setting / Configuración de parámetros	by LCD - Display
Auto-Restart / Rearmado automático	✓
Anti-dust kit / Kit filtro anti polvo	x
Remote LCD / Panel LCD remoto	✓
Mounting / Montaje	Wall mounting / En pared
<b>AC INPUT / ENTRADA CA</b>	
Voltage / Tensión	230 VAC
Input Range / Rango de entrada	110-280VAC
Max. Input Voltage / Voltage Máx. de Entrada	300VAC
Input frequency / Frecuencia de entrada	50Hz / 60Hz Auto sensing - (46Hz - 64Hz)
Power Factor / Factor de Potencia	>0.98
AC Generator / Motogenerador C.A.	AC input compatible with generator / Entrada compatible con moto-generadores
Phase / Fases	1 phase / 1 fase: 220/230 VAC (L-N)
<b>OUTPUT / SALIDA</b>	
Voltage Output / Voltaje de Salida AC	230VAC
Output Regulation / Regulación de Salida	+/- 5% (battery mode / modo batería)
Transfer Time / Tiempo de Transferencia	Line Mode to Battery Mode / Modo Línea a Modo Batería : 0 mSeg Inverter Mode to Bypass / Modo Inversor a Bypass: 4 mSeg
Waveform / Forma de Onda	Pure Sinewave / Sinusoidal Pura
Output Current / Corriente de Salida	23 A MAX.
<b>EFFICIENCY / EFICIENCIA</b>	
Inverter Efficiency / Eficiencia del inversor	90%
Line mode Efficiency / Eficiencia modo línea	93%
No load consumption / Consumo interno sin carga	<75W
<b>OVERLOAD/ SOBRECARGA</b>	
Overload protection / Protección alto consumo	(105% to 150%: 10s) / (>150%: 5s)
Surge Power / Potencia Máxima	10.000 W (5s)
<b>PROTECTIONS</b>	
Short circuit Protection / Protección cortos	Line mode: Breaker / Battery mode: Electronic protection
Input Current / Corriente de Entrada	Circuit Breaker / Disyuntor
<b>BATTERIES / BATERIAS</b>	
Type / Tipo	Sealed Lead Acid / Sellada de Libre Mantenimiento: VRLA, AGM, GEL, USER & LiFePO4
Rated Voltage / Tensión DC nominal (VDC)	48
Operative DC Range / Rango DC Operativo	40-66 VDC
Low DC warning / Aviso batería baja (VDC)	Load>50%: 44.0 VDC Load<50%: 45.0 VDC
Low DC shutdown / Apagado por batería baja	Load>50%: 42.0 VDC Load<50%: 43.0 VDC
High DC shutdown / Apagado por batería alta	66.0 VDC
Cold start / Arranque en frío	> 46.0 VDC
Battery Current / Corriente de baterías	125 A MAX.
<b>USER INTERFACE / INTERFAZ CON EL USUARIO</b>	
LCD & LED	AC&PV Inputs, Output, Load (%), Battery level, Charging status (%), Operation mode, etc Valores de entrada AC y Solar, Salida, Consumo, Batería, Cargador, Modo de operación, etc
<b>ALARM / ALARMAS</b>	
Alarm Beep / Alarma Sonora	Beep alarm is activated to warn about alarms / Alarma sonora para anunciar alarmas
Alarm Codes / Mensajes de Alarma	Alarm & fault codes are displayed on LCD / Mensajes de alarma y error mostrados en el LCD

### XSI-B-230V-MPP (P5)

## Technical Specifications

### XSI-B - SOLAR INVERTER 230V - MPP (2/2)

### 5KP-48-MPP

#### CHARGERS (SOLAR & AC)

Solar charger type / Cargador solar	MPPT
Charging procedure / Tipo de recarga	3 steps: 1-Constant Current (Bulk), 2-Constant Voltage, 3-Floating
Data for VRLA Batteries / Datos para Baterías VRLA	
Bulk Charging / Voltaje cargador (Etapa Bulk)	AGM: 58.4 VDC - AGM/GEL: 56.4
Floating Charging / Voltaje cargador (Etapa Floating)	54 VDC
Overcharge Protection / Protección Sobrecarga	66 VDC
Max. PV Power / Potencia Max. Entrada PV	4000 W
Max. PV VOC / Voltaje en abierto paneles (VOC)	145 VDC
PV Array MPPT Range / Rango MPPT	60 to 115 VDC
Solar charger Amps / Corriente cargador solar	80A MAX.
AC charger Amps / Corriente cargador CA	2/10/20/30/40/50/60A
Total charging Amps / Total corriente cargador	140 A MAX.
Efficiency / Eficiencia	98% MAX

#### CONNECTIONS / CONEXIONES

AC Main / Entrada CA (L-N-G)	Hard wired / Regleta
AC Output / Salida CA (L-N-G)	Hard wired / Regleta
Battery Input / Entrada de Baterías (+) & (-)	Hard wired / Regleta
Solar Panel Input / Entrada Panel Solar (+) & (-)	Hard wired / Regleta

#### SAFETY / SEGURIDAD

Safety certifications / Certificados de Seguridad	CE
---	----

#### PHYSICAL / FISICAS: UPS

DxWxH / Prof.x Ancho x Altura	140 x 303 x 525 (mm)
Net Weight / Peso Neto (kgs)	13.5
Pack Dimensions DxWxH / Dim. Empacado PrxAnxAl	600 x 400 x 220 (mm)

#### OPERATIONAL CONDITIONS / CONDICIONES DE OPERACIÓN

Installation Site / Lugar Instalación	IP20 (Indoor / Ambiente Interior)
Rel. Humidity / Humedad Relativa	< 95 % RH (non-condensing / no condensante)
Operating Temperature / Temperatura Operación	0 to 55 °c
Storage Temperature / Temperatura Almacenaje	-15 to 60 °C
Audible Noise / Ruido Audible	<60dB

Max. Altitude / Altura de Operación Max.

4,500 meters over sea level / sobre nivel del mar.  
 \* Power output de-rate of 1% every 100m (over 1.500m)  
 \* Disminución de potencia de 1% cada 100m (sobre los 1.500m)

#### COMMUNICATION / COMUNICACION

USB	Built-in (incorporado)
RS232	Built-in (incorporado)
Dry Contacts / Contactos secos	Built-in (incorporado)
SNMP (LAN Ethernet)	Optional (Opcional)
Modbus RS485	Optional (Opcional)

Software

Available for Windows family, Linux 32 & 64bits, MAC 64bits. Main functions: Monitor multiple inverters, data and event logs, alarm messages and remote configuration for inverters  
 Disponible para Windows, Linux 32 & 64bits, MAC 64bits. Funciones principales: Supervisión de múltiples inversores, registro de datos y eventos, mensajes de alarma y configuración remota.

Technical specifications can be modified to comply with special requirements / Las especificaciones pueden, bajo requerimiento, adaptarse a proyectos especiales

Technical specifications may change without further notice / Por motivos comerciales o técnicos las especificaciones pueden cambiar sin previo aviso.

This inverter family requires battery connection to operate. See details in chapter 5 in User Manual.

Esta familia de inversores requiere conexión a las baterías para operar en cualquier condición. Ver detalles en la sección 5 del Manual de Usuario.

## Solar Inverter

### XSI OGP 3K/5K

High efficiency Solar inverter with pure sinewave output either for 220Vac or two-phase 120Vac systems. Thanks to robust and modern design, XSI inverters can operate in environmentally hostile sites.

100% On-Grid operation allows feeding the grid with all solar electric production from PV panels. Counts on several communication possibilities and control software.

### Features

- 100% On-Grid Operation
- High efficiency performance thanks to MPPT technology
- Microprocessor and DSP based design
- Pure sine-wave output
- High conversion efficiency, up to 96%
- Multiple communication ports and control software
- Cold-start and automatic restart
- Compatible with monocrystalline and polycrystalline solar panels
- Modular design for maintenance purposes
- Manufactured with industrial grade components for a robust operation
- Data register for up to 15 years
- Local and remote monitoring thanks to communication options and software, downloadable from our web site
- Anti-Islanding protection, for safer and more reliable operation and maintenance of equipment and installation.



**AC 220V** For 220V or Two-phase 120V

**100% On-Grid Operation**

**Multi Comm** Several options for Local & Remote Communication

**Product 3 YEARS** 3 years warranty

### 100% On-Grid Operation

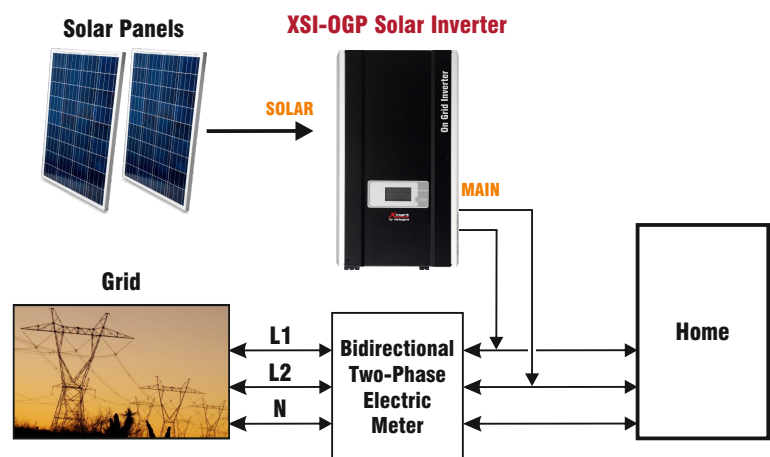

# Solar Inverter

# XSI-OGP 3K/5K

## Features

### Solar Input

#### Wide Range of Operation

A wide range of voltage on Solar Input allows this inverter family to operate efficiently and keeps an optimum AC output even during big voltage variation from solar panels.

100 - 500VDC

#### Alto VOC (Voltaje Máximo en Abierto Paneles Solares)

High value in VOC allows working with a larger solar panel array with serial connection, easing the installation and achieving higher levels of solar power, with lower current.

500 VDC



### Safety and efficiency in On-Grid operation

Complying with directives such as VDE-AR-N 4105 & EN62109-2, this inverter follows-up real-time variation on grid for a safe operation.

Folow-up is made on: Voltage (In range: 184 to 264VAC), Frequency (-2.5Hz to +1.5Hz), and ground leak current.

Controlling these three parameters allow generating a safe, reliable and efficient grid feeding

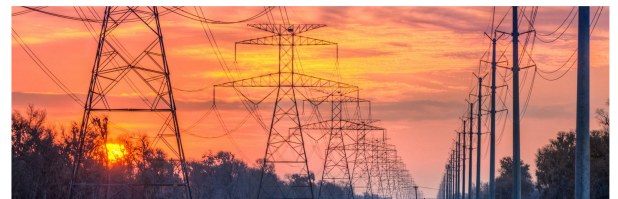

### Excellent design for domestic applications

A robust, reliable, and stylish design, as well as simple installation, makes this Inverter family the perfect solution for electric cogeneration, monetizing your asset.



### Communication and Software

#### Multiple Communication Channels

This inverter family includes USB and RS-232 communication ports, as well as dry contact interface. Moreover, there are additional options: LAN-Ethernet, Modbus, and GPRS mobile communication.

#### Software

Xmart software, specific for XSI inverters, is available for most Operating Systems: Windows, Linux (32&64) y MAC 64 bits. Our software allows consulting the inverter status, power sources, load; as well as configuring all adjustable parameters, and recording data, alarms and, system events.

### Additional Features

#### Digital Screen

A smart LCD informs in real time about inverter's operation, showing: Operating status, solar input voltage, voltage, frequency y power generated by the inverter, as well as Logs of the power feeded to the grid in different time periods.

#### Smart Self-Diagnostic System

Inverter operation is constantly self-monitored to detect potential warning or fault situations which are visually reported on LCD screen along with sound alarms, easing diagnostic and maintenance tasks.

## Technical Specifications / Especificaciones Técnicas

XSI - SOLAR INVERTER - PURE ON-GRID	XSI-OGP-3K-NB	XSI-OGP-5K-NB
<b>MAIN FEATURES / FUNCIONALIDADES</b>		
Built-in Charger / Cargador incorporado	MPPT	
Technology / Tecnología	On-Grid design only / 100% On-Grid	
Parameters setting / Configuración de parámetros	Via Software (SolarPower)	
<b>ON-GRID / OPERACIÓN ALIMENTANDO LA RED</b>		
Max. Feeding Power / Potencia Max. A la Red	3.000 W	5.000 W
Nominal Output / Voltaje de Salida (L-N) VAC	230 VAC	
AC Grid / Conexión a Red CA	L-N-G	
PV Input / Entrada Solar	Terminal Block / Regleta de Conexión (+ / -)	
Output Voltage Range / Rango de Voltaje de Salida	184 to 264 VAC (Note 1)	
Output Frequency Range / Rango de Frecuencia de Salida	47.5 to 51.5 Hz (Note 1)	
Max. Output Current / Corriente de Salida Máxima	16.3 A	27.1 A
Start On-Grid Max. Current / Imáx. al Iniciar On-Grid	13 A x 20 mSec	21.7 A x 20 mSec
Max Overcurrent Protection / Protección Corriente máx.	52 A	
Max. Efficiency DC/AC - Eficiencia Max.	96%	
Output Current Distorsion / Distorsión de Salida	<3%	
<b>PV INPUT / ENTRADA PANELES SOLARES</b>		
Max. PV Power / Potencia Máx. Solar	3.150 W	5.300 W
Max. PV VOC / Máx. Voltaje en Abierto (Voc)	500VDC	
MPPT Range / Rango MPPT	100 - 500 VDC (@ full load)	
Full Power MPPT Range / Rango MPPT Máxima Potencia	250 - 450 VDC (@ full load)	300 - 450 VDC (@ full load)
Start-up PV Voltage / Tensión Solar de Arranque	125 VDC +/- 10V	130 VDC +/- 10V
Shut-down PV Voltage / Tensión de apagado Solar	70 VDC +/- 10V	
<b>BATTERIES / BATERÍAS</b>		
Batteries / Baterías	Operation without Batteries / Operación sin baterías	
<b>PROTECTIONS / PROTECCIONES</b>		
Built-In / Incluidas de Fábrica	AC Output Short Circuit, Ground Fault, Grid Monitoring, DC Reverse connection / Cortocircuitos Salida, Falla en Tierra, Monitoreo de la red, Conexión inversa DC	
<b>SAFETY / SEGURIDAD</b>		
Safety certifications / Certificados de Seguridad	CE	
EMC	IEC 61000-3-11, IEC 61000-3-12, IEC 61000-6-2, IEC 61000-6-3	
Low Voltage Regulation / Baja tensión	IEC 62109-1, IEC 62109-2, AS/NZS 3100	
<b>PHYSICAL / FISICAS</b>		
Net Dimensions / Dimensiones Netas (mm)	285*125*480	
Gross Dimensions / Dimensiones Empacado (mm)	600*345*255	
Net Weight / Peso Neto (kgs)	9.5	9.8
Gross Weight / Peso Empacado (kgs)	11.2	11.5
<b>OPERATIONAL CONDITIONS / CONDICIONES DE OPERACIÓN</b>		
Temp. & Rel. Humidity / Temp. & Humedad Relativa	-10 to 40°C // 0 to 95% (non condensing / no condensante)	
Operating Temperature / Temperatura Operación	-10 to 40°C	
Storage Temperature / Temperatura Almacenaje	-15 to 60 °C	
Cooling / Enfriamiento	Forced cooling / Mediante ventiladores	
Protection & Mounting / Protección & Montaje	IP-20 (indoor/Interiores) // Wall mounting / Montaje en pared	
Max. Altitude / Altura de Operación Max.	4.500 m (over 1.000m : 1% derate every 100m)	
<b>COMMUNICATION / COMUNICACION</b>		
Built-In / Incluidas	USB & RS232	
Options / Opciones	SNMP (LAN Ethernet), Modbus RS485, GPRS	
Software	SolarPower, available in our web / SolarPower, disponible en nuestra web	

Technical specifications can be modified to comply with special requirements / Las especificaciones pueden, bajo requerimiento, adaptarse a proyectos  
 Technical specifications may change without further notice / Por motivos comerciales o técnicos las especificaciones pueden cambiar sin previo aviso.

Note 1: Grid voltage and Frequency range may vary depending on country grid standard. Both can be adjusted through SolarPower software.

Nota 1: Los Rangos de Frecuencia y Voltaje de línea (Grid) pueden variar según el estándar del país. Ambos se ajustan mediante el software SolarPower.

## Solar Inverter

# XSI-2PLV-MPP 6KP/10KP

High efficiency Solar inverter with pure sine-wave output for 120Vac 2-Phase systems. Thanks to robust and modern design, XSI inverters can operate in electrically and environmentally hostile sites. Counts on 2 smart and powerful chargers, one MPPT powered by Solar Input and another powered by AC Input.

Avantgarde technology allows to be simultaneously fed by AC Input and Solar Input. Priority of usage for these two inputs can be configured by the user. Includes several communication possibilities and control software.

### Features

- Microprocessor based design
- Pure sine-wave output, adjustable to: 110V or 120V
- Designed for outdoors installation: IP65. Waterproof and Dustproof.
- Parallel installation up to 6 units, either for capacity increasing or for redundancy purposes.
- When operating in parallel systems, inverters can share batteries.
- Built-in communication port for BMS (RS485)
- Adjustable schedule for power outlets turning on & off, as well as battery charger operation
- Smart internal chargers: Solar (MPPT) and AC
- Configurable usage priority for multiple inputs:
  - Solar Panels
  - AC Line (Grid)
  - Batteries
- Fully compatible with Power Generators
- Multiple communication ports and control software
- Cold Start and y Auto Restart
- Compatible with all kind of solar panels
- Compatible with two-phase systems (L1, L2, & N) with 120° or 180° configurable phase-shift (Split-phase).
- Supports LiFePO4 batteries



- AC 120V** 120V Two-phase Input and Output
-  Pure Sine-wave output
- DUAL CHGR** Dual charger AC and Solar MPPT
- Product 2 YEARS** 2 years warranty

### Operation with different power supplies

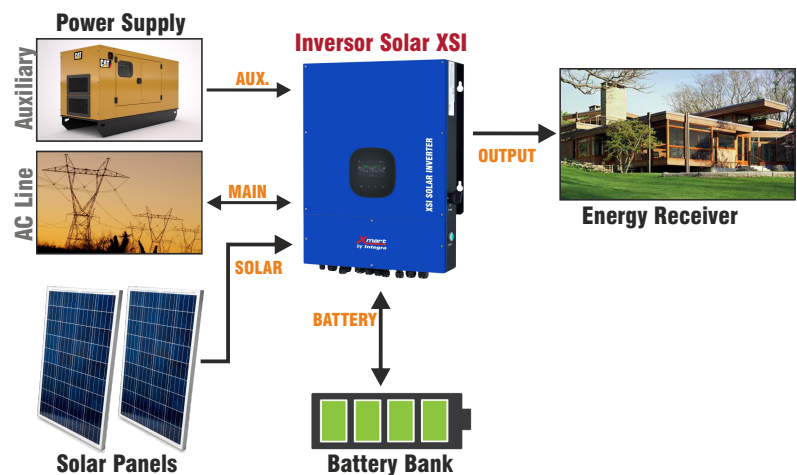

# Solar Inverter

# XSI-2PLV-MPP 6KP/10KP

## Features

### Solar Input

#### Wide Range of Operation

A wide range of voltage on Solar Input helps to charge batteries efficiently and keeps an optimum AC output even during big voltage variation from solar panels.

MPPT Range:  
120V - 550V

#### High VOC (Solar Panel Open Circuit Voltage)

High value in VOC allows working with a larger solar panel array with serial connection, easing the installation and achieving higher levels of solar power, with lower current.

Voc: 600 VDC



### AC Input

#### Perfect Operation Voltage Range for Dual Mode

A wide AC Input range (85 to 140Vac L-N), for Off-Grid operation and an ideal range (105.5 to 132Vac) for On-Grid operation.

#### Compatible with Power Generators

XSI inverters can work direct with Power Generators for a more reliable and flexible performance for your installation.



### 3 Stages internal Smart Battery Chargers

#### MPPT Solar Charger

This Inverter series includes MPPT (max. power point tracking) Technology Solar Charger to optimize the batteries charging capacity even during big changes of solar input.

**Corriente Max:**  
6K: 120A  
10K: 200A

#### AC Charger

AC Charger is powered by AC input. A high adjustable charging current fulfils all your battery bank needs.

**Corriente Max:**  
6K: 120A  
10K: 200A

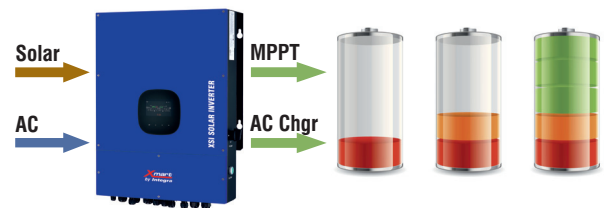

### Additional Features

- Hybrid inverter, able to operate either on off-grid mode or "grid-tie" mode to feed main AC line.
- Multiple Input lines available: Solar, AC & Batteries. Use priority is configurable from the front panel.
- Output voltage can be adjusted to 110Vac or 120Vac.
- Scheduled power outlets turn On/Off system or battery chargers.
- High efficiency MPPT technology battery chargers.
- Cold Start: Inverter can start operating without power (neither AC nor Solar) as long as batteries are charged.

### Communication and Software

#### Multiple Communication Channels

This inverter family includes USB and RS-232 communication ports, as well as dry contact interface. Moreover, can be remotely monitored via Ethernet, directly from your web browser thanks to our SNMP Cards.

#### Software

Xsmart software, specific for XSI inverters, is available for most Operating Systems: Windows, Linux (32&64) and MAC 64 bits. Our software allows consulting the inverter status, power sources, load; as well as configuring all adjustable parameters, and recording data, alarms, and system events.

## Technical Specifications / Especificaciones Técnicas

XSI - SOLAR INVERTER 2PLV 120V - (1/2)	6KP	10KP
Output Capacity / Capacidad de Salida (VA/KW)	6KVA / 6KW	10KVA / 10KW
<b>MAIN FEATURES / FUNCIONALIDADES</b>		
Type / Tipo	Hybrid inverter off-grid & grid-tie op. / Inversor Híbrido, operación off-grid & grid-tie	
Built-in Solar Charger / Cargador Solar incorporado	MPPT	
Max. PV Input Power / Max. KW Entrada	7.5KW	12KW
Max. PV Open Circuit / Voltaje Open Circuit max.	600 VDC	
Start-Up Voltage / Voltaje de Arranque	125VDC	
Max. DC Power MPPT Range / Rango Operacional MPPT	120VDC to 550VDC	
Quantity of MPPT Input / Cantidad de Entradas MPPT	2	
Max. Input Current x String / Corriente Máx. x String	I <sub>max</sub> String 1 = I <sub>max</sub> String 2 = 15A      I <sub>max</sub> String 1 = I <sub>max</sub> String 2 = 18A	
Max. Input Current x MPPT / Corriente Máx. x MPPT	I Max Total (MPPT1 + MPPT2) = 30A	
Inputs Priority / Prioridad de Entradas	Configurable	
No load consumption / Consumo interno sin carga	<120W	<150W
Parameters setting / Configuración de parámetros	by LCD - Display	
Auto-Restart / Rearmado automático	Built-In / Incluido	
Mounting / Montaje	Wall / Pared	
Parallel Installation / Instalación en Paralelo	Up to 6 units (Built-In) / Hasta 6 unidades (Incluido)	
<b>GRID-TIE OPERATION / OPERACION GRID-TIE</b>		
<b>PV INPUT / ENTRADA PANELES SOLARES</b>		
Initial Feeding Voltage/Voltaje Mínimo para Grid-Tie	160VDC	
<b>GRID OUTPUT / ALIMENTACION A LA RED AC</b>		
Nominal Voltage / Tensión Nominal	110VAC - 120VAC (L-N) / 208VAC (L1-L2, @120°) / 240VAC (L1-L2, @180°)	
Output Range / Rango de Salida	105.5VAC - 132 VAC (L-N)	
Output frequency / Frecuencia de Salida	47.5 - 51.5 Hz or/o 59.3 - 60.5Hz	
Nominal Output Current / Corriente Nominal de Salida	25A per Phase / por Fase	41.7A per Phase / por Fase
Power Factor / Factor de Potencia	0.9 lag to 0.9 lead / de 0.9 En Atraso a 0.9 En Adelanto	
Efficiency / Eficiencia	96.5%	
<b>OFF-GRID OPERATION / OPERACION OFF-GRID</b>		
<b>AC INPUT / ENTRADA AC</b>		
Input Voltage Range / Rango de Tensión de Entrada	85 - 140 VAC Per Phase / Por Fase	
Nominal Frequency / Frecuencia para la red	50Hz or/o 60Hz (autosensing)	
AC Start-up Voltage / Voltaje AC de Arranque	85VAC	
Auto-Restart Voltage / Voltaje de Rearmado Automático	90VAC	
Max. AC Input Current / Corriente Max. Entrada	40A (Ph)	60A (Ph)
<b>BATTERY MODE / MODO BATERÍA</b>		
Nominal Power Output / Salida Nominal (KW)	6KW	10KW
Nominal Output Voltage / Voltaje Nominal Salida (Vac)	110VAC - 120VAC (L-N) / 208VAC (L1-L2, 120°) / 240VAC (L1-L2, 180°)	
Nominal Output Frequency / Frec. Nominal Salida (Hz)	50Hz/60Hz configurable	
Max Efficiency / Eficiencia Máxima (DC/AC)	91%	
Waveform / Forma de Onda	Pure Sine Wave / Sinusoidal Pura	
<b>OVERLOAD/ SOBRECARGA</b>		
Line Mode / Modo Normal	<110%: OK >110% & In Curr<40A: Overload & Alarm In Curr>40A (1 Ph): Fuse / Fusible	<110%: OK >110% & In Curr<50A: Overload & Alarm In Curr>50A (1 Ph): Fuse / Fusible
Battery Mode / Modo Batería	<110%: OK >110%&< 150%: Overload Alarm 1m, then Fault/ Alarma por 1m, luego Falla >150%&< 200%: Overload Alarm 30s, then Fault/ Alarma por 30 S, luego Falla > 200%: Immediate Fault / Modo Falla inmediato	
<b>USER INTERFACE / INTERFAZ CON EL USUARIO</b>		
LCD	AC&PV Inputs, Output, Load (%), Battery level & Type, Charger, Op. Mode. Entrada AC y Solar, Salida, Consumo, Tipo de Baterías, Cargador, Modo de Op.	
<b>ALARM / ALARMAS</b>		
Alarm Beep / Alarma Sonora:	Beep warn about alarms / Avisos de alarma sonora	
Alarm Codes / Mensajes de Alarma	Alarm codes are displayed on LCD / El LCD muestra los códigos de alarma	

## Technical Specifications / Especificaciones Técnicas

XSI - SOLAR INVERTER 2PLV 120V - (2/2)	6KP	10KP
<b>PROTECTIONS</b>		
Short circuit Protection / Protección cortos	Line mode: Fuse / Battery mode: Software Detection // Modo Online: Fusible / Modo Batería / Detección por Software	
Others / Otros	AC Overload, Ground & Grid Fault Monitoring, Batt. Charging Mgmt, AC Short Circuit. / Sobrecarga, Superv. de Falla de Tierra y de línea, Control de Carga de Bat., Cortos.	
<b>BATTERIES / BATERIAS</b>		
Type / Tipo	VRLA, GEL, Lithium (PYLONTECH, WECO, SOLTARO), LiFePO4, & User Defined	
Rated Voltage / Tensión DC nominal	48 VDC	
Max. Discharge Current / Corriente Máxima de Descarga	150A	200A
Low DC warning / Aviso batería baja	44VDC (Adjustable / Configurable)	
Low DC shutdown / Apagado por batería baja	42VDC (Adjustable / Configurable)	
Cold start / Arranque en frío	> 48.0 VDC	
<b>CHARGERS (SOLAR &amp; AC)</b>		
Solar charger type / Cargador solar	MPPT	
Charging procedure / Tipo de recarga	3 Steps: 1-Constant Current, 2-Constant Voltage, 3-Floating, According to DIN41773 / 3 Fases: 1-Corriente Constante, 2-Voltaje Constante, 3-Flotante, Según DIN41773	
Nominal DC Voltage / Voltaje DC Nominal	48VDC	
Floating Charging / Voltaje cargador (Etapa Floating)	54.0 VDC (Adjustable / Configurable)	
Absorption Charging / Voltaje Carga (Etapa Constant Volt.)	56.4 VDC (Adjustable / Configurable)	
Solar charger Amps / Corriente cargador solar	120 A MAX.	200 A MAX.
AC charger Amps / Corriente cargador CA	120 A MAX.	200 A MAX.
Total charging Amps / Total corriente de recarga	120 A MAX.	200 A MAX.
<b>CONNECTIONS / CONEXIONES</b>		
AC Main / Entrada CA	Hard wired / Regleta: L1-L2-N-G	
AC Output / Salida CA	Hard wired / Regleta: L1-L2-N-G	
Battery Input / Entrada de Baterías	Hard wired / Regleta: +/-	
Solar Panel Input / Entrada Panel Solar	Hard wired / Regleta: 2x POS (+) & 2x NEG (-) By each MPPT / Por cada MPPT	
<b>SAFETY / SEGURIDAD</b>		
Safety certifications / Certificados de Seguridad	CE, UL1741	
<b>PHYSICAL / FISICAS:</b>		
Unit DxWxH / Prof.*Ancho*Altura (mm)	215.5 * 515 * 700 mm	215.5 * 515 * 715 mm
Unit Net Weight / Peso Neto (kgs)	41	46,5
Packing DxWxH / Prof.*Ancho*Altura (mm)	310 * 655 * 820 mm	310 * 655 * 820 mm
Packing Gross Weight / Peso Neto (kgs)	45	50,5
<b>OPERATIONAL CONDITIONS / CONDICIONES DE OPERACIÓN</b>		
Installation Site / Lugar Instalación	IP65 (Outdoors / Exterior)	
Rel. Humidity / Humedad Relativa	Storage/Almacenaje: < 90 % RH (non-condensing / no condensante) Operation/Operación: < 100% (non-condensing / no condensante)	
Operating Temperature / Temperatura Operación	-25 to 60 °C	
Storage Temperature / Temperatura Almacenaje	-25 to 60 °C	
Audible Noise / Ruido Acústico	<50 dB @ 1m	
Max. Altitude / Altura de Operación Max.	4.500 meters over sea level / sobre nivel del mar. * Output power derates 1% every 100m (over 1.000m) * Disminución de potencia de 1% cada 100m (sobre los 1.000m)	
<b>COMMUNICATION / COMUNICACION</b>		
USB	Built-in / incorporado	
RS232	Built-in / incorporado	
Dry Contacts / Contactos secos	Low battery / Aviso de baterías bajas	
Software	For Windows family, Linux 32 & 64bits, MAC 64bits. Includes Monitor multiple inverters, data and event logs, alarm messages and remote configuration for inverters Para Windows, Linux 32 & 64bits, MAC 64bits. Incluye: Supervisión de múltiples inversores, registro de datos y eventos, mensajes de alarma y configuración remota.	

Technical specifications can be modified to comply with special requirements / Las especificaciones pueden, bajo requerimiento, adaptarse a proyectos especiales

Technical specifications may change without further notice / Por motivos comerciales o técnicos las especificaciones pueden cambiar sin previo aviso.

This inverter can function without batteries according to power conditions. See details in section 5 of User Manual.

Este inversor puede operar sin baterías dependiendo de las condiciones de alimentación. Ver detalles en el capítulo 5 del Manual de Usuario.

## Solar Inverter

# XSI-3P-400V-MPP 6KW/9KW/15KW

High efficiency Solar inverter with pure sine-wave output for 3-phases 400/230Vac systems. Thanks to their robust and modern design, XSI inverters can operate in electrically and environmentally hostile sites. Counts on 2 smart and powerful chargers, one MPPT powered by Solar Input and another powered by AC Input. Avantgarde technology allows to be simultaneously fed by AC Input and Solar Input. Priority of usage for these two inputs can be configured by the user. Includes several communication possibilities and control software.

### Características Principales

- Design based on microprocessors and DSP
- Pure sine-wave output, adjustable to: 380/220V, 400/230V, or 415/240V
- High efficiency conversion
- Adjustable schedule for power outlets turning on & off
- Smart internal chargers: Solar (MPPT) and AC
- Configurable priority of usage for multiple inputs:
  - Solar Panels
  - AC Line (Grid)
  - Batteries
- Fully compatible with Power Generators
- Multiple communication ports and control software
- Cold Start and y Auto Restart
- Compatible with all kind of solar panels



**AC 230V** 400/230V Three-phase Input and Output

Pure Sine-wave output

**DUAL CHGR** Dual charger AC and Solar MPPT

**Product 2 YEARS** 3 years warranty

### Operation with different power supplies

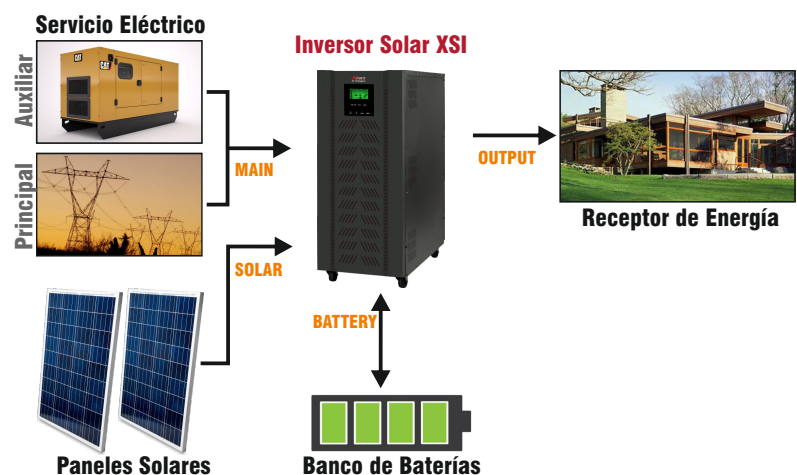

# Solar Inverter

# XSI-3P-400-MPP 6K/9K/15K

## Features

### Solar Input

#### Wide Range of Operation

A wide range of voltage on Solar Input helps to charge batteries efficiently and keeps an optimum AC output even during big voltage variation from solar panels.

MPPT Range:  
120V - 430V

#### High VOC (Solar Panel Open Circuit Voltage)

High value in VOC allows working with a larger solar panel array with serial connection, easing the installation and achieving higher levels of solar power, with lower current.

Voc: 450 VDC



### AC Input

#### Extra Wide Operation Voltage Range

Inverter can be configured to operate with a wide AC Input range: 90 to 280Vac (L-N)

#### Compatible with Power Generators

XSI inverters can filter voltage fluctuation from Power Generators to generate clean and pure sine-wave power for your equipment



### 3 Stages internal Smart Battery Chargers

#### MPPT Solar Charger

This Inverter series includes 3 MPPT (max. power point tracking) Technology Solar Chargers to optimize the batteries charging capacity even during big changes of solar input.

**Max. Current:**  
60A each MPPT

#### AC Charger

AC Charger is powered by input AC. A high adjustable charging current fulfills all needs of your battery bank.

**Max. Current:**  
60A per Phase



### Additional Features

- Hybrid inverter, able to operate either on off-grid mode or "grid-tie" mode to feed main AC line.
- Multiple Input lines available: Solar, AC & Batteries. Use priority is configurable from the front panel.
- Output voltage can be adjusted to 380/220Vac, 400/230Vac, or 415/240Vac.
- Scheduled power outlets turn On/Off system.
- High efficiency MPPT technology battery chargers.
- Cold Start: Inverter can start operating without power (neither AC nor Solar) as long as batteries are charged.

### Communication and Software

#### Multiple Communication Channels

This inverter family includes USB and RS-232 communication ports, as well as dry contact interface. Moreover, there are additional options: LAN-Ethernet, Modbus, WiFi, and GPRS mobile communication.

#### Software

Xsmart software, specific for XSI inverters, is available for most Operating Systems: Windows, Linux (32&64) and MAC 64 bits. Our software allows consulting the inverter status, power sources, load; as well as configuring all adjustable parameters, and recording data, alarms, and system events.

## Technical Specifications / Especificaciones Técnicas

XSI - SOLAR INVERTER 3P 400/230V - (1/2)	6K	9K	15K
Output Capacity / Capacidad de Salida (VA/KW)	6KVA / 6KW	9KVA / 9KW	15KVA / 15KW
<b>PV INPUT / ENTRADA PANELES SOLARES</b>			
Max. PV Power (per input) / KW Max. por cada entrada	3KW	4KW	5KW
Max. Input Current (each MPPT) / Amperios Max. por MPPT	13A	18A	18A
Max. PV Open Circuit / Voltaje Open Circuit max.	450 VDC		
Max. MPPT Range / Rango Operacional MPPT	225VDC to 430VDC	225VDC to 430VDC	275VDC to 430VDC
Quantity of Input MPPT / MPPT de Entrada	3		
<b>MAIN FEATURES / FUNCIONALIDADES</b>			
Type / Tipo	Hybrid inverter (dual off-grid and grid-tie) // Híbrido (off-grid & grid-tie)		
Built-in Solar Charger / Cargador Solar incorporado	MPPT		
Inputs Priority / Prioridad de Entradas	Configurable		
Parameters setting / Configuración de parámetros	by LCD - Display		
Auto-Restart / Rearmado automático	✓		
Mounting / Montaje	Tower / Torre		
<b>AC INPUT / ENTRADA CA</b>			
Voltage / Tensión	3 Phases (380/220V ; 400/230V ; 415/240V)		
Input Wiring / Cableado de Entrada	L1, L2, L3, N + G		
Input Range / Rango de entrada	Selectable / Seleccionable: Wide Range Mode: (90-280VAC L-N) / PC Mode: (170-280VAC L-N)		
Input frequency / Frecuencia de entrada	50Hz / 60Hz Auto sensing - (40Hz - 65Hz)		
AC Generator / Motogenerador C.A.	AC input compatible with generator / Entrada compatible con moto-generadores		
<b>AC OUTPUT (GRID TIE) / SALIDA CA (GRID TIE)</b>			
Nominal Voltage / Voltaje para la red	3 phases: 380/220V , 400/230V , 415/240V (configurable)		
Nominal Frequency / Frecuencia para la red	50Hz or 60Hz (autosensing)		
Feed-in Grid Voltage Range / Rango Voltaje para la red	195 to 253 Vac (Indian regulation) // 184 to 264.5 Vac German regulation)		
Feed-in Grid Freq. Range / Rango Frecuencia para la red	49 to 51 Hz (Indian regulation) // 47.5 to 51.5 Hz German regulation)		
Max. Output Current / Corriente Max. Salida	9A	13A	22A
Max Efficiency / Eficiencia Máxima (PV/AC)	95%		
Output Shortcircuit / Cortocircuito a la salida	Breaker / porotección por disyuntor		
<b>BATTERY MODE / MODO BATERÍA</b>			
Nominal Power Output / Salida Nominal (KW)	2KW per phase	3KW per phase	5KW per phase
Nominal Voltage Output / Salida Nominal (Vac)	220/230/240Vac (L-N) // 50Hz/60Hz configurable		
Max Efficiency / Eficiencia Máxima (PV/AC)	93%		
No load consumption / Consumo interno sin carga	<135W		
Overload / Sobrecarga a la salida	(110-150%): 1min // (151%-200%): 10s // (>200%): 1s		
Output Shortcircuit / Cortocircuito a la salida	Power-of (4 cycles) // Se apagan las salidas en 4 ciclos		
<b>OVERLOAD/ SOBRECARGA</b>			
Overload protection / Protección alto consumo	(<105%: 0K) / (105% to 150%: 10s) / (>150%: 5s)		
Surge Power / Potencia Máxima	2.000 VA (5s)	4.000 VA (5s)	6.000 VA (5s)
<b>PROTECTIONS</b>			
Short circuit Protection / Protección cortos	Line mode: Breaker / Battery mode: Electronic protection		
Input Current / Corriente de Entrada	Circuit Breaker / Disyuntor		
<b>BATTERIES / BATERIAS</b>			
Type / Tipo	VRLA-AGM, GEL, USER		
Rated Voltage / Tensión DC nominal	48 VDC		
Low DC warning / Aviso batería baja	(LOAD < 20%: 44.0VDC) // (20% < LOAD < 50%: 42.8VDC) // (LOAD > 50%: 40.4VDC)		
Low DC shutdown / Apagado por batería baja	(LOAD < 20%: 42.0VDC) // (20% < LOAD < 50%: 40.8VDC) // (LOAD > 50%: 38.4VDC)		
Cold start / Arranque en frío	> 46.0 VDC		
<b>USER INTERFACE / INTERFAZ CON EL USUARIO</b>			
LCD & 3 LED	AC&PV Inputs, Output, Load (%), Battery level, Charging status (%), Operation mode, etc Valores de entrada AC y Solar, Salida, Consumo, Batería, Cargador, Modo de operación, etc		
<b>ALARM / ALARMAS</b>			
Alarm Beep / Alarma Sonora:	Beep alarm is activated to warn about alarms / Alarma sonora para anunciar alarmas		
Alarm Codes / Mensajes de Alarma	Alarm codes are displayed on LCD / Los mensajes de alarma se muestran en pantalla		

## Technical Specifications / Especificaciones Técnicas

XSI - SOLAR INVERTER 3P 400/230V - (2/2)	6K	9K	15K
<b>CHARGERS (SOLAR &amp; AC)</b>			
Solar charger type / Cargador solar	MPPT		
Charging procedure / Tipo de recarga	3 steps: 1-Constant Current, 2-Constant Voltage, 3-Floating		
Floating Charging / Voltaje cargador (Etapa Floating)	54.0 VDC		
Absorption Charging / Voltaje Carga (Etapa Constant Volt.)	56.4 VDC		
Solar charger Amps / Corriente cargador solar	60 A MAX (each // cada uno)		
AC charger Amps / Corriente cargador CA	60 A MAX (each phase // por cada fase)		
Total charging Amps / Total corriente de recarga	180 A MAX.		
<b>CONNECTIONS / CONEXIONES</b>			
AC Main / Entrada CA	Hard wired / Regleta (L1-L2-L3-N-G)		
AC Output / Salida CA	Hard wired / Regleta (L1-L2-L3-N-G)		
Battery Input / Entrada de Baterías	Hard wired / Regleta (+/-)		
Solar Panel Input / Entrada Panel Solar	Hard wired / Regleta: PV1: (+ / -), PV2: (+ / -), PV3: (+ / -)		
<b>SAFETY / SEGURIDAD</b>			
Safety certifications / Certificados de Seguridad	CE		
<b>PHYSICAL / FISICAS:</b>			
DxWxH / Prof.*Ancho*Altura (mm)	590 * 260 * 650 mm		
Net Weight / Peso Neto (kgs)	36	38	40
<b>OPERATIONAL CONDITIONS / CONDICIONES DE OPERACIÓN</b>			
Rel. Humidity / Humedad Relativa	< 95 % RH (non-condensing / no condensante)		
Operating Temperature / Temperatura Operación	-10 to 50 °C		
Storage Temperature / Temperatura Almacenaje	-15 to 60 °C		
Audible Noise / Ruido Acústico	<60 dB @ 1m		
Max. Altitude / Altura de Operación Max.	4.500 meters over sea level / sobre nivel del mar. * Power output de-rate of 1% every 100m (over 1.500m) * Disminución de potencia de 1% cada 100m (sobre los 1.500m)		
<b>COMMUNICATION / COMUNICACION</b>			
USB	Built-in (incorporado)		
RS232	Built-in (incorporado)		
Dry Contacts / Contactos secos	✓ (Low battery / Aviso de baterías bajas)		
SNMP (LAN Ethernet)	Optional (Opcional)		
Software	Available for Windows family, Linux 32 & 64bits, MAC 64bits. Main functions: Monitor multiple inverters, data and event logs, alarm messages and remote configuration for inverters Disponibles para Windows, Linux 32 & 64bits, MAC 64bits. Funciones principales: Supervisión de múltiples inversores, registro de datos y eventos, mensajes de alarma y configuración remota.		

Technical specifications can be modified to comply with special requirements / Las especificaciones pueden, bajo requerimiento, adaptarse a proyectos especiales  
 Technical specifications may change without further notice / Por motivos comerciales o técnicos las especificaciones pueden cambiar sin previo aviso.



## Solar Inverter

# XSI-3PW-MPP 10KW/12KW/15KW/30KW

High efficiency Solar inverter with pure sine-wave output for 3-phases 400/230Vac systems. Thanks to their robust and modern design, XSI inverter can operate in electrically and environmentally hostile sites. Includes a powerful smart internal battery charger system for solar inputs (MPPT) as well as AC input.

Avant-garde technology allows to be simultaneously fed by AC Input and Solar Input. Priority of usage for these two inputs can be configured by the user. Includes several communication possibilities and control software. Supports parallel operation, up to 4 units, either for capacity growth or for redundancy purposes.

### Features

- Design based on microprocessors and DSP
- Pure sine-wave output, adjustable to: 360/208V, 380/220V, 400/230V, or 415/240V
- Designed for outdoors installations: IP65
- High efficiency conversion
- Adjustable schedule for power outlets turning on & off
- Smart internal chargers: Solar (MPPT) and AC
- Configurable priority of usage for multiple inputs:
  - Solar Panels
  - AC Line (Grid)
  - Batteries
- Fully compatible with Power Generators
- Multiple communication ports and control software
- Cold Start and y Auto Restart
- Compatible with all kind of solar panels



400/230V Three-phase Input and Output



Pure Sine-wave output



Dual charger AC and Solar MPPT



2 years warranty

### Operation with different power supplies

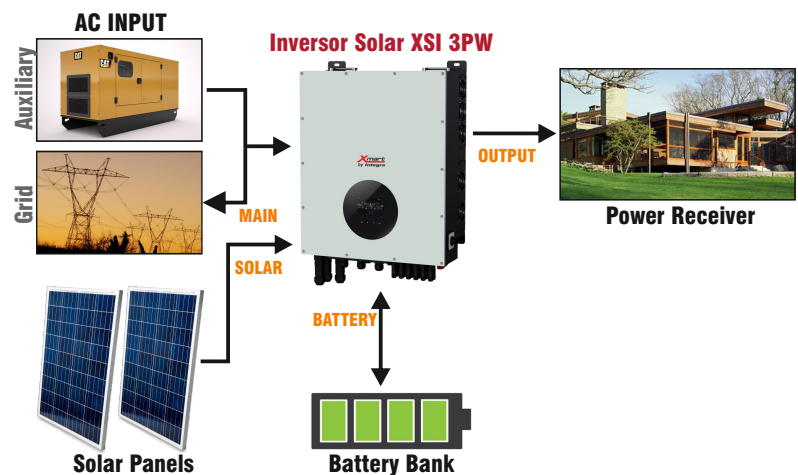

# Solar Inverter

# XSI-3PW-MPP 12KW/15KW/30KW

## Features

### Solar Input

#### Wide Range of Operation

A wide range of voltage on Solar Input helps to charge batteries efficiently and keeps an optimum AC output even during big voltage variation from solar panels.

MPPT Range:  
350V - 950V

#### High VOC (Solar Panel Open Circuit Voltage)

High value in VOC allows working with a larger solar panel array with serial connection, easing the installation and achieving higher levels of solar power, with lower current.

Voc: 1000 VDC



### AC Input

#### Extra Wide Operation Voltage Range

Inverter can be configured to operate with a wide AC Input range: 170 to 290Vac.

#### Compatible with Power Generators

XSI inverters can be powered not only by Grid, but also by auxiliary systems (power generator)



### 3 Stages internal Smart Battery Chargers

#### MPPT Solar Charger

This Inverter series includes 2 MPPT (max. power point tracking) Technology modules to optimize the batteries charging capacity even during big changes of solar input.

#### AC Charger

AC input is added to solar input for charging purposes. A high adjustable charging current fulfills all needs of your battery bank.

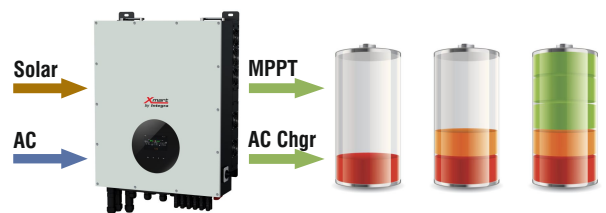

### Additional Features

- Hybrid inverter, able to operate either on off-grid mode or "grid-tie" mode to feed main AC line.
- Parallel operation, up to 6 units, either for capacity growth or for redundancy purposes (up to 4 units for 30KW model).
- Multiple Input lines available: Solar, AC & Batteries. Use priority is configurable from the front panel.
- Output voltage can be adjusted to 360/208Vac, 380/220Vac, 400/230Vac, or 415/240Vac.
- Scheduled power outlets turn On/Off system.
- High efficiency MPPT technology battery chargers.
- Cold Start: Inverter can start operating without power (neither AC nor Solar) as long as batteries are charged.

### Communication and Software

#### Multiple Communication Channels

This inverter family includes USB and RS-232 communication ports, as well as dry contact interface. Moreover, there are additional options: LAN-Ethernet, Modbus, WiFi, and GPRS mobile communication.

#### Software

Xsmart software, specific for XSI inverters, is available for most Operating Systems: Windows, Linux (32&64) and MAC 64 bits. Our software allows consulting the inverter status, power sources, load; as well as configuring all adjustable parameters, and recording data, alarms, and system events.

## Technical Specifications / Especificaciones Técnicas

XSI - SOLAR INVERTER 3PW 400/230V - (1/2)	10KP	12KP	15KP
Output Capacity / Capacidad de Salida (KVA/KW)	10KVA / 10KW	12KVA / 12KW	15KVA / 15KW
<b>PV INPUT / ENTRADA PANELES SOLARES</b>			
Max. PV Power / KW Max.	14,5KW	16KW	22,5KW
Max. Input Current (per MPPT) / Corriente Max. x MPPT		26A (13A+13A)	
Nominal DC Voltage / Voltaje DC Nominal		720VDC	
Max. PV Open Circuit / Voltaje Open Circuit max.		1000 VDC	
Max. MPPT Range / Rango Operacional MPPT		350VDC to 950VDC (+/-10VDC)	
Full Load MPPT Range / Rango MPPT a Plena Carga		348 - 900VDC	
Quantity of Input MPPT / MPPT de Entrada		2	
<b>MAIN FEATURES / FUNCIONALIDADES</b>			
Type / Tipo	Hybrid inverter (dual off-grid and grid-tie) // Híbrido (off-grid & grid-tie)		
Built-in Solar Charger / Cargador Solar incorporado	MPPT		
Inputs Priority / Prioridad de Entradas	Configurable		
Parameters setting / Configuración de parámetros	Via Software & LCD		
Auto-Restart / Rearmado automático	Si		
Mounting / Montaje	Wall / Pared		
Parallel Operation up to / Operación en Paralelo hasta	Up to 6 units (Built-In) / Hasta 6 unidades (De fábrica)		
<b>AC INPUT / ENTRADA CA</b>			
Voltage / Tensión	3 Phases (380/220Vac ; 400/230Vac ; 415/240Vac)		
Input Wiring / Cableado de Entrada	L1, L2, L3, N + G		
Input Range / Rango de entrada	170-290Vac L-N		
Max AC Input Current / Corriente Máx de Entrada	40 Amp per phase / por fase		
Input frequency / Frecuencia de entrada	50Hz / 60Hz Auto sensing - (40Hz - 65Hz)		
AC Generator / Motogenerador C.A.	AC input compatible with generator / Entrada compatible con moto-generadores		
<b>AC OUTPUT (GRID TIE) / SALIDA CA (GRID TIE)</b>			
Nominal Voltage / Voltaje para la red (3 phases)	380/220Vac , 400/230Vac , 415/240Vac (configurable)		
Nominal Frequency / Frecuencia para la red	50Hz or 60Hz (autosensing)		
Feed-in Grid Voltage Range / Rango Voltaje para la red	184 to 264.5 Vac (According to chosen Standar / Según el Estándar escogido)		
Feed-in Grid Freq. Range / Rango Frec. para la red	47.5 to 51.5 Hz (According to chosen Standar / Según el Estándar escogido)		
Max. Output Current / Corriente Max. Salida (per Phase)	14.5A	17.4A	21.7A
Max Efficiency / Eficiencia Máxima (PV/AC)	95%		
Output Shortcircuit / Cortocircuito a la salida	Fuse / Protección por fusible		
<b>BATTERY MODE / MODO BATERIA</b>			
Nominal Power Output / Salida Nominal (KW)	3,33KW per phase	4KW per phase	5KW per phase
Nominal Voltage Output / Salida Nominal (Vac)	208 / 220 / 230 / 240Vac (L-N) // 50Hz/60Hz (Configurable)		
Output Voltage Distorsion / Distorsión voltaje salida	(THDv): <3% Linear Load / Carga Lineal // <5% Non-Linear Load (Carga no Lineal)		
Max Efficiency / Eficiencia Máxima (PV/AC)	91%		
No load consumption / Consumo interno sin carga	<180W		
Overload / Sobrecarga a la salida	(110-150%): 1min // (151%-200%): 30s // (>201%): <1s		
Output Shortcircuit / Cortocircuito a la salida	Power-off (4 cycles) // Se apagan las salidas en 4 ciclos		
<b>OVERLOAD/ SOBRECARGA</b>			
Overload protection / Protección alto consumo	(<110%: OK) / (111% to 200%: Sound and LCD Warning) / (>201%: <1s)		
Surge Power / Potencia Adicional	10KW	12KW	15KW
<b>PROTECTIONS</b>			
Short circuit Protection / Protección cortos	Line mode: Fuse / Battery mode: Software Detection		
Other / Otros	AC Overload Protection, Ground Fault Monitoring, Grid Monitoring, Battery Charging Management Protección Sobrecarga AC, Supervisión de Falla de Aterramiento y de la línea AC, Control de Recarga Bat.		
<b>BATTERIES / BATERIAS</b>			
Type / Tipo	LITHIUM, User Defined / Definidas por el Usuario		
Rated Voltage / Tensión DC nominal	48 VDC		
Low DC warning / Aviso batería baja	44.0VDC		
Low DC shutdown / Apagado por batería baja	42.0VDC		
Cold start / Arranque en frío	48.0VDC		
<b>USER INTERFACE / INTERFAZ CON EL USUARIO</b>			
LCD	AC&PV Inputs, Output, Load (%), Battery level, Charger, Operation mode, etc Valores de entrada AC y Solar, Salida, Consumo, Batería, Cargador, Modo de operación, etc		
<b>ALARM / ALARMAS</b>			
Alarm Beep / Alarma Sonora:	Beep alarm warns about alarms / Alarma sonora para anunciar alarmas		
Alarm Codes / Mensajes de Alarma	Alarm codes are displayed on LCD / Los códigos de alarma se muestran en pantalla		

## Technical Specifications / Especificaciones Técnicas

XSI - SOLAR INVERTER 3PW 400/230V - (2/2)	10KP	12KP	15KP
<b>CHARGERS (SOLAR &amp; AC)</b>			
Solar charger type / Cargador solar	MPPT		
Charging procedure / Tipo de recarga	3 steps: 1-Constant Current, 2-Constant Voltage, 3-Floating		
Floating Charging / Voltaje Etapa Flotante	54.0 VDC		
Absorption Charging / Voltaje Carga	56.0 VDC (Constant Voltage Stage / Etapa Voltaje Constante)		
Max. Battery Discharge Current / Corriente Máx. de Descarga	250 A MAX.	300 A MAX.	375 A MAX.
Total charging Amps / Corriente de recarga total Solar, Grid, or Solar + Grid	200 A MAX.	250 A MAX.	300 A MAX.
<b>CONNECTIONS / CONEXIONES</b>			
AC Main / Entrada CA	Tree Phase Connector / Conector Trifásico (L1-L2-L3-N-G)		
AC Output / Salida CA	Tree Phase Connector / Conector Trifásico (L1-L2-L3-N-G)		
Battery Input / Entrada de Baterías	Battery Plug / Terminales (+/-)		
Solar Panel Input / Entrada Panel Solar	MC4 Connectors / Conectores MC4 : 2x PV1, 2x PV2 (+/- each)		
<b>SAFETY / SEGURIDAD</b>			
Safety certifications / Certificados de Seguridad	CE		
<b>PHYSICAL / FISICAS:</b>			
HxWxD / Altura*Ancho* Prof. (mm)	750 * 660 * 255		
Net Weight / Peso Neto (kgs)	70	70	73
<b>OPERATIONAL CONDITIONS / CONDICIONES DE OPERACION</b>			
Installation Site / Lugar Instalación	IP65 (Outdoor. Avoid direct solar light / Exteriores. Evitar luz solar directa)		
Rel. Humidity / Humedad Relativa	0 to 100% (Non-cond.)		
Operating Temperature / Temperatura Operación	-25 to 60 °C		
Storage Temperature / Temperatura Almacenaje	-40 to 60 °C		
Audible Noise / Ruido Acústico	<50 dB @ 1m		
Max. Altitude / Altura de Operación Max.	4.500 meters over sea level / sobre nivel del mar. * Power output derating of 1% every 100m (over 1.500m) * Disminución de potencia de 1% cada 100m (sobre los 1.500m)		
<b>COMMUNICATION / COMUNICACION</b>			
USB, RS232, RS485, CAN, WI-FI	Built-in (incorporado)		
Dry Contacts / Contactos secos	(Low battery / Aviso de baterías bajas)		
SNMP (LAN Ethernet), ModBus	Optional (Opcional)		
Software	Available for Windows family, Linux 32 & 64bits, MAC 64bits. Main functions: Monitor multiple inverters, data and event logs, alarm messages and remote configuration. Disponibles para Windows, Linux 32 & 64bits, MAC 64bits. Funciones principales: Supervisión de múltiples inversores, registro de datos y eventos, mensajes de alarma y configuración remota.		

Technical specifications can be modified to comply with special requirements / Las especificaciones pueden, bajo requerimiento, adaptarse a proyectos especiales

Technical specifications may change without further notice / Por motivos comerciales o técnicos las especificaciones pueden cambiar sin previo aviso.

This inverter family might require battery connection to operate in some conditions. See details in chapter 5 in User Manual.

Esta familia de inversores podría requerir conexión a las baterías para operar en algunas condiciones. Ver detalles en la sección 5 del Manual de Usuario.



## Technical Specifications / Especificaciones Técnicas

<b>XSI - SOLAR INVERTER 3PW 400/230V - (1/2)</b>	<b>30KP</b>
Output Capacity / Capacidad de Salida (KVA/KW)	30KVA / 30KW
<b>PV INPUT / ENTRADA PANELES SOLARES</b>	
Max. PV Power / KW Máx.	40KW
Max. Input Current (per MPPT) / Corriente Max. x MPPT	13A + 13A
Nominal DC Voltage / Voltaje Dc Nominal	720VDC
Max. PV Open Circuit / Voltaje Open Circuit max.	1000 VDC
Max. MPPT Range / Rango Operacional MPPT	350VDC to 900VDC (±10VDC)
Full Load MPPT Range / Rango MPPT a Plena Carga	500 - 900VDC
Quantity of Input MPPT / MPPT de Entrada	3
<b>MAIN FEATURES / FUNCIONALIDADES</b>	
Type / Tipo	Hybrid inverter (dual off-grid and grid-tie) // Híbrido (off-grid & grid-tie)
Built-in Solar Charger / Cargador Solar incorporado	MPPT
Inputs Priority / Prioridad de Entradas	Configurable
Parameters setting / Configuración de parámetros	Via Software & LCD
Auto-Restart / Rearmado automático	Si
Mounting / Montaje	Wall / Pared
Parallel Operation up to / Operación en Paralelo hasta	Up to 4 units (Built-In) / Hasta 4 unidades (De fábrica)
<b>AC INPUT OFF-GRID / ENTRADA CA OFF-GRID</b>	
Input Wiring / Cableado de Entrada	L1, L2, L3, N + G
Input Range / Rango de entrada	170-290Vac L-N
Max AC Input Current / Corriente Máx de Entrada	60 Amp per phase / por fase
Input frequency / Frecuencia de entrada	50Hz/ 60Hz (Autosensing)
<b>GENERATOR INPUT / ENTRADA MOTOGENERADOR</b>	
Input Wiring / Cableado de Entrada	L1, L2, L3, N + G
Input Range / Rango de entrada	170-290Vac L-N
Max AC Input Current / Corriente Máx de Entrada	60A (Por fase)
Input frequency Range / Frecuencia de entrada (Rango)	40 to 50Hz / 60 to 70Hz
<b>AC OUTPUT GRID-TIE / SALIDA CA GRID-TIE</b>	
Nominal Voltage / Voltaje para la red (3 phases)	380/220Vac , 400/230Vac , 415/240Vac (configurable)
Nominal Frequency / Frecuencia para la red	50Hz or 60Hz (autosensing)
Feed-in Grid Voltage Range / Rango voltaje para la red	195 to 253 Vac (Indian regulation) // 184 to 264.5 Vac German regulation)
Feed-in Grid Freq. Range / Rango Frec. para la red	49 to 51 Hz (Indian regulation) // 47.5 to 51.5 Hz German regulation)
Nominal Output Current / Corriente salida Nominal	43.5A (Por fase)
Max Efficiency / Eficiencia máxima (PV/AC)	96.5%
Output Shortcircuit / Cortocircuito a la salida	Breaker & Software Detection
<b>BATTERY MODE / MODO BATERIA</b>	
Nominal Power Output / Salida nominal (KW)	10KW per phase
Output Waveform / Forma de onda de salida	Pure Sinewave / Sinusoidal pura
Nominal Voltage Output / Salida nominal (Vac)	220 / 230 / 240Vac (L-N) // 50Hz/60Hz configurable
Output Voltage Distorsion / Distorsión voltaje salida	(THDv): <3% Linear Load / Carga Lineal // <5% Non-Linear Load (Carga no Lineal)
Max Efficiency / Eficiencia Máxima (PV/AC)	96%
No load consumption / Consumo interno sin carga	250W
Overload / Sobrecarga a la salida	(110-150%): 1min // (151%-200%): 30s // (>201%): <1s
Output Shortcircuit / Cortocircuito a la salida	Power-off (4 cycles) // Se apagan las salidas en 4 ciclos
<b>OVERLOAD/ SOBRECARGA</b>	
Overload protection / Protección alto consumo	(<110%: OK) / (111% to 200%: Sound and LCD Warning) / (>201%: <1s)
Surge Power / Potencia adicional	30,000 VA
<b>PROTECTIONS</b>	
Short circuit Protection / Protección cortos	Line Mode: Breaker / Battery Mode: Software Detection
Other / Otros	AC Overload Protection, Ground Fault Monitoring, Grid Monitoring, Battery Charging Management Protección Sobrecarga AC, Supervisión de Falla de Aterramiento y de la línea AC, Control de Recarga de Baterías

## Technical Specifications / Especificaciones Técnicas

XSI - SOLAR INVERTER 3PW 400/230V - (2/2)	30KP
<b>BATTERIES / BATERIAS</b>	
Type / Tipo	VRLA-AGM, GEL, LITHIUM, USER
Rated Voltage / Tensión DC nominal	736VDC
Low DC warning / Aviso batería baja	717VDC
Low DC shutdown / Apagado por batería baja	667VDC
Cold start / Arranque en frío	736VDC
<b>USER INTERFACE / INTERFAZ CON EL USUARIO</b>	
LCD	AC&PV Inputs, Output, Load (%), Battery level, Charger, Operation mode, Warning, Fault, etc Datos de entrada AC y Solar, Salida, Consumo, Batería, Cargador, Modo de operación, Alarmas, etc
<b>ALARM / ALARMAS</b>	
Alarm Beep / Alarma Sonora:	Beep alarm warns about alarms / Alarma sonora para anunciar alarmas
Alarm Codes / Mensajes de Alarma	Alarm codes are displayed on LCD / Los códigos de alarma se muestran en pantalla
<b>CHARGERS (SOLAR &amp; AC)</b>	
Solar charger type / Cargador solar	MPPT
Charging procedure / Tipo de recarga	3 steps: 1-Constant Current, 2-Constant Voltage, 3-Floating
Floating Charging / Voltaje Etapa Flotante	828 VDC
Absorption Charging / Voltaje Carga	828 VDC
Total charging Amps / Corriente de recarga total	80 A MAX. (Solar, Grid, or Solar + Grid)
<b>CONNECTIONS / CONEXIONES</b>	
AC Main / Entrada CA	Tree Phase Connector / Conector Trifásico (L1-L2-L3-N-G)
AC Output / Salida CA	Tree Phase Connector / Conector Trifásico (L1-L2-L3-N-G)
Battery Input / Entrada de Baterías	Battery Plug / Terminales (+/-)
Solar Panel Input / Entrada Panel Solar	MC4 Connectors / Conectores MC4 : 2x PV1, 2x PV2, 2x PV3 (+/- each)
<b>SAFETY / SEGURIDAD</b>	
Safety certifications / Certificados de Seguridad	CE
<b>PHYSICAL / FISICAS:</b>	
HxWxD / Altura*Ancho* Prof. (mm)	750 * 660 * 255
Net Weight / Peso Neto (kgs)	73
<b>OPERATIONAL CONDITIONS / CONDICIONES DE OPERACION</b>	
Installation Site / Lugar Instalación	IP65 (Outdoor. Avoid direct solar light / Exteriores. Evitar luz solar directa)
Rel. Humidity / Humedad Relativa	0 to 95% (Non-cond.)
Operating Temperature / Temperatura Operación	-25 to 60 °C
Storage Temperature / Temperatura Almacenaje	-40 to 60 °C
Audible Noise / Ruido Acústico	<50 dB @ 1m
Max. Altitude / Altura de Operación Max.	4.500 meters over sea level / sobre nivel del mar. * Power output derating of 1% every 100m (over 1.500m) * Disminución de potencia de 1% cada 100m (sobre los 1.500m)
<b>COMMUNICATION / COMUNICACION</b>	
USB, RS232, RS485, CAN, WI-FI	Built-in (incorporado)
Dry Contacts / Contactos secos	(Low battery / Aviso de baterías bajas)
SNMP (LAN Ethernet), ModBus	Optional (Opcional)

Available for Windows family, Linux 32 & 64bits, MAC 64bits. Main functions: Monitor multiple inverters, data and event logs, alarm messages and remote configuration.

### Software

Disponible para Windows, Linux 32 & 64bits, MAC 64bits. Funciones principales: Supervisión y configuración local y remota, registro de datos y eventos, mensajes de alarma.

Technical specifications can be modified to comply with special requirements / Las especificaciones pueden, bajo requerimiento, adaptarse a proyectos especiales

Technical specifications may change without further notice / Por motivos comerciales o técnicos las especificaciones pueden cambiar sin previo aviso.

This inverter family might require battery connection to operate in some conditions. See details in chapter 5 in User Manual.

Esta familia de inversores podría requerir conexión a las baterías para operar en algunas condiciones. Ver detalles en la sección 5 del Manual de Usuario.





## **XSI-PPS - PORTABLE POWER STATION**

High-Quality Electrical Energy, Available Anywhere, Anytime, to Power Any of Your Devices.

Store Energy from the Electrical Grid, Solar Light, or a Generator, to then power your devices whenever and wherever you need it.

Xmart's XSI-PPS Power Stations include Solar Technology, a Modern, Robust, Transportable Design, and LFP Batteries; perfectly adapted for Domestic, Commercial, and Office environments. Cutting-edge Technology at your disposal.

# XSI-PPS-1.2K / 2.5K / 3K PORTABLE POWER STATIONS

Our **XSI-PPS** are rechargeable stations from multiple electrical sources (Grid, Solar Panels, Generators), which can in turn power your devices offering safe, stable, and convenient operation.

No installation required, they are 100% Plug & Play.

Additionally, they are easily transportable and have direct connection for your devices, thanks to their USB Type A and C ports, which support QC and PD charging protocols.

High technology at your fingertips.



**XSI-PPS-1.2KW**

**XSI-PPS-3KW**



Our **XSI-PPS** can power your equipment, appliances, or devices, even during power outages, just like a UPS.

You can recharge its batteries during off-peak hours, and then power your equipment during peak hours, generating operational savings.

Equipped with Grade A LiFePO4 batteries, ensuring a longer lifespan and many more discharge cycles than conventional batteries.

The best technology available on the market.

Our **XSI-PPS** are perfect energy solutions whether for fun or work at home, offices, businesses of all kinds, and even outdoor adventures, for camping with the comfort of having all your equipment and devices with the best power supply available. It has never been so easy to take advantage of portable solar panels.

Hours of work or entertainment, thanks to our energy technology, in a practical, comfortable, lightweight, transportable, and Plug & Play design.



# XSI-PPS

## PORTABLE POWER STATION



1.2K and 2.5K **XSI-PPS** are excellent power stations, allowing you to power your equipment directly from their output sockets or charge your devices from their USB Type A and C ports, or directly from their wireless charger, thus offering a wide variety of benefits and opportunities, even during power outages.

Their modern and portable design allows them to be used in both indoor and outdoor environments.

Additionally, the **XSI-PPS** can be managed both from our supervision and control software, and from the app on your mobile device, always in real-time.

### XSI-PPS-1.2K / 2.5K

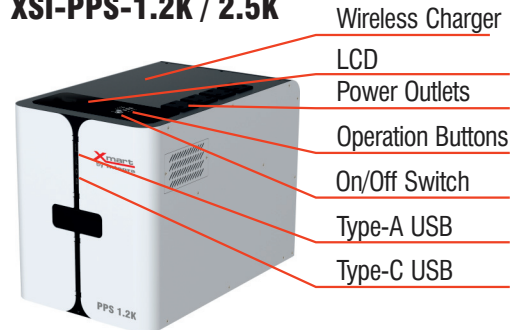

Thanks to their hybrid technology, 1.2K and 2.5K **XSI-PPS** can charge their powerful LiFePO4 batteries from mobile or fixed solar panels, and then power your equipment when needed by harnessing the most sustainable energy of all: Solar Light.

However, their adaptability allows them to also draw power from the power grid and even from generators, managing energy to your equipment with a pure sine wave signal while charging their internal batteries.

Their wheels, weight, and design make them easily transportable to the site where they will provide the best service, and their built-in dust filters protect them to provide better service.

## TECHNICAL FEATURES:

- Battery Type: LiFePO4

---

- Battery Capacity:
  - XSI-PPS 1.2KW: 768Wh
  - XSI-PPS 2.5KW: 1536Wh

---

- Battery Protection: BMS

---

- Battery Life: > 2500 Cycles (@EOL 100% DoD)

---

- Solar Input Nominal Voltage: 240Vdc

---

- Grid Feed-In: Optional

---

- Reverse Polarity Protection for Solar Input

---

- USB-A Charge Ports: 2x 18W QC

---

- USB-C Charge Ports: 2x 65W PD 3.0

---

- Wireless Charger: 15W

---

- Power Outlets: Schuko or Universal

---

- Operation Voltage: 230Vac

### TOP VIEW

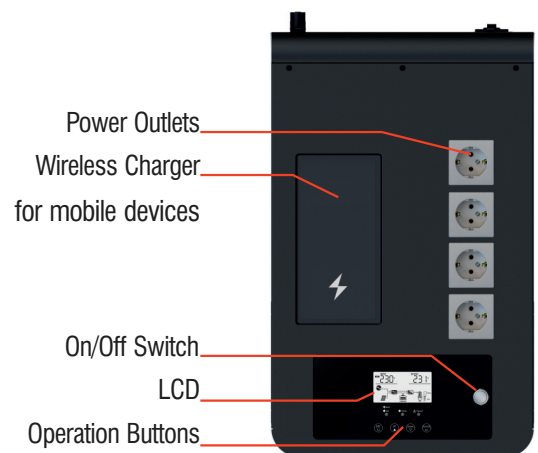

# XSI-PPS PORTABLE POWER STATION

**XSI-PPS 3K** model, in addition to powering your equipment directly from its output sockets or charging your devices from its USB Type A and C ports, allows for the addition of extra battery packs, expanding its backup capacity from 2500Wh to 7500Wh.

Moreover, they can also be installed in parallel for simultaneous operation, enabling them to power many more devices or a single larger piece of equipment.

They can also be managed both from our supervision and control software, and from the app on your mobile device, always in real-time.

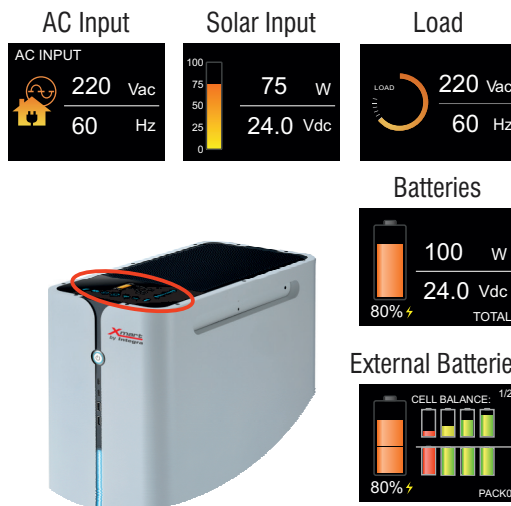
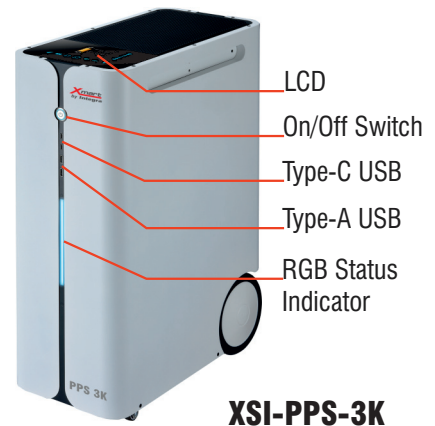

The modern color screen of the **XSI-PPS 3K** is touch-sensitive and constantly displays the relevant data from the electrical grid or the solar panel system it is powered by, as well as the batteries, both internal and external, connected to this powerful power station.

Additionally, it allows for the configuration of the unit to faithfully adjust it to your requirements.

Its wheels, weight, and design make it easily transportable to the site where it will provide the best service, and its built-in dust filters protect it to ensure better performance.

## TECHNICAL FEATURES:

Battery Type: LiFePO4

Expansion Capacity:

- Additional Batteries: Up to 2 Packs
- Parallel Units: Up to 2 units

Internal Battery Capacity: 2560Wh

External Packs Capacity: 2560Wh

Battery Protection: BMS

Battery Life: > 3500 Cycles (@EOL 100% DoD)

Nominal Solar Input Voltage: 240Vdc

Reverse Polarity Protection on Solar Input

USB-A Charging Ports: 2x 18W QC

USB-C Charging Ports: 2x 65W PD 3.0

Power Outlets: Schuko or Universal + Terminal Block

Available Versions: 120Vac and 230Vac

## REAR VIEW

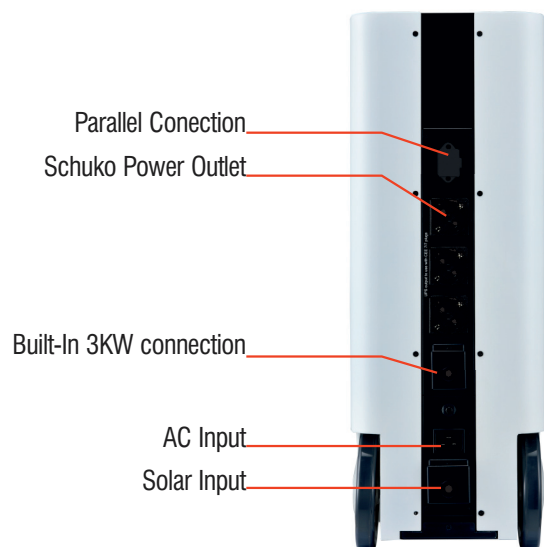

# XSI-PPS

## PORTABLE POWER STATION



XSI-PPS-3K  
Capacity: 2.5KWh

XSI-PPS-3K +  
XBAT-PPS-LFP-2.5KWh  
Capacity: 5KWh

XSI-PPS-3K +  
2 XBAT-PPS-LFP-2.5KWh  
Capacity: 7.5KWh

### External Batteries - XBAT-PPS-LFP-2.5KWh

**XSI-PPS-3K** includes internal LiFePO4 batteries with a capacity of 2.5KWh.

Additionally, it allows the connection of up to 2 additional external batteries of the **XBAT-PPS-LFP-2.5KWh** model, to expand its backup capacity to 7.5KWh.

With its modern BMS (Battery Management System), **XSI-PPS-3K** can efficiently and safely manage all its batteries, including daily discharges over the long life that distinguishes LFP batteries from standard ones (VRLA).

### Operación en Paralelo

**XSI-PPS 3K** allows for up to 2 units to be connected in parallel to power more equipment, larger equipment, or increase autonomy. When the rear panels are connected, they coordinate and power your devices.

This can be done whether the Power Stations have external batteries or not, even if the number of external batteries for each **XSI-PPS 3K** differs. Maximum achievable battery capacity is 15KWh.

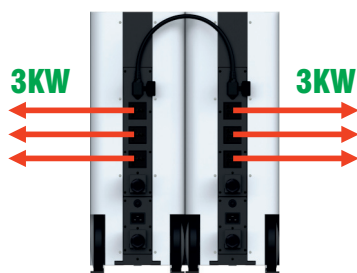

6KW to power several  
equipment.  
Battery Capacity: 5KWh

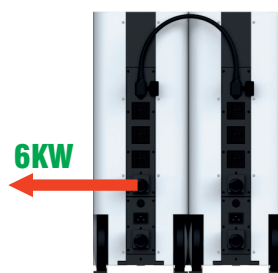

6KW to power 1 single equipment.  
Battery Capacity: 5KWh



6KW to power several equipment.  
Battery Capacity: 12.5KWh

With this great power and battery capacity, you can support the operation of:

- Household Appliances: From lighting and TV to refrigeration or air conditioning, including entertainment equipment, internet, home office, gaming, video surveillance, etc.
- Office and Commercial Equipment: IT equipment, CCTV, point of sale terminals, etc.
- Camping: Heaters, stoves, music, etc.

### Moreover...

**XSI-PPS 3K** can charge its batteries to 90% in just one hour, whether from its Solar input or from the electrical grid, thanks to its powerful chargers and BMS system.

It allows you to export its event log via its communication USB port.

It supports firmware updates directly from its App.

It can be configured to operate in the most effective way, according to the operating conditions of your installation, from its screen, via software, or from its App.



# WHAT EQUIPMENT TO BACK UP? FOR HOW LONG?

**XSI-PPS 3K** can power various types of equipment in numerous environments, even without electrical power, thanks to its modern internal batteries.

Let's look at some examples, as practical as they are convenient, of the type of equipment that can be powered by the **XSI-PPS 3K**.

The examples presented below show the expected backup time of the **XSI-PPS 3K** with its internal batteries, although it should be noted that original capacity of our Power Station (2.5KWh) can be expanded up to 15KWh.



**Refrigerator:**

Power: 120 W  
Backup: 15h to 30h

Depending on the operation mode



**Air Conditioner:**

Power: 1300 W  
Backup: 01h 45m

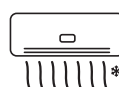

**Lamp:**

Power: 20 W  
Backup: 46h 30m



**Desktop PC:**

Power: 300 W  
Backup: 07h 03m



**Laptop:**

Power: 100 W  
Recharges: 40

Laptop with 50Wh battery



**Router (WiFi):**

Power: 15 W  
Backup: 51h 40m



**Microwaves:**

Power: 1000 W  
Backup: 01h 58m

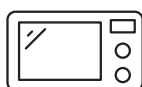

**TV:**

Power: 140 W  
Backup: 13h 45m



**Smartphone:**

Power: > 19 W  
Recharges: > 1700

Mobiles with quick charge (1 to 1.5h) & Battery > 12Wh



**Fan:**

Power: 40 W  
Backup: 33h 15m



**Oil Heater:**

Power: 700 W  
Backup: 03h 15m



These backups can be expanded by adding **XBAT-PPS-LFP-2.5KWh** batteries. Additionally, the system's watt capacity can be doubled by installing a second **XSI-PPS 3K** in parallel, or both can be done, bringing the total capacity to 6KW and 15KWh.



## **XBAT-PPS-LFP-2.5KWh - TECHNICAL FEATURES:**

Battery Type: LiFePO4

Battery Capacity: 2560Wh

Operation and Protection System: BMS

Active Communication with XSI-PPS-3K via BMS

Battery Life: > 3500 Cycles (@EOL 100% DoD)

Indicator LEDs: Capacity

Wheel Break: Included

Specialized Connectors and Cables: Included

Identification System for Parallel Operation: Included

# HOW TO USE IT PERMANENTLY?

**XSI-PPS 3K** does not require any special installation, it's as simple as turning it on and starting to use it. Additionally, its portability makes it the ideal companion for temporary use wherever needed.

However, its ease of being powered by solar sources or power grid during off-peak hours makes it a logical solution to power your most valuable either equipment every day or only when power fails.

The following diagram shows a proposal for permanent installation in your home, office, or business, with which you can power your most valuable equipment from the **XSI-PPS 3K** Power Station, leaving a separate line for less important equipment.

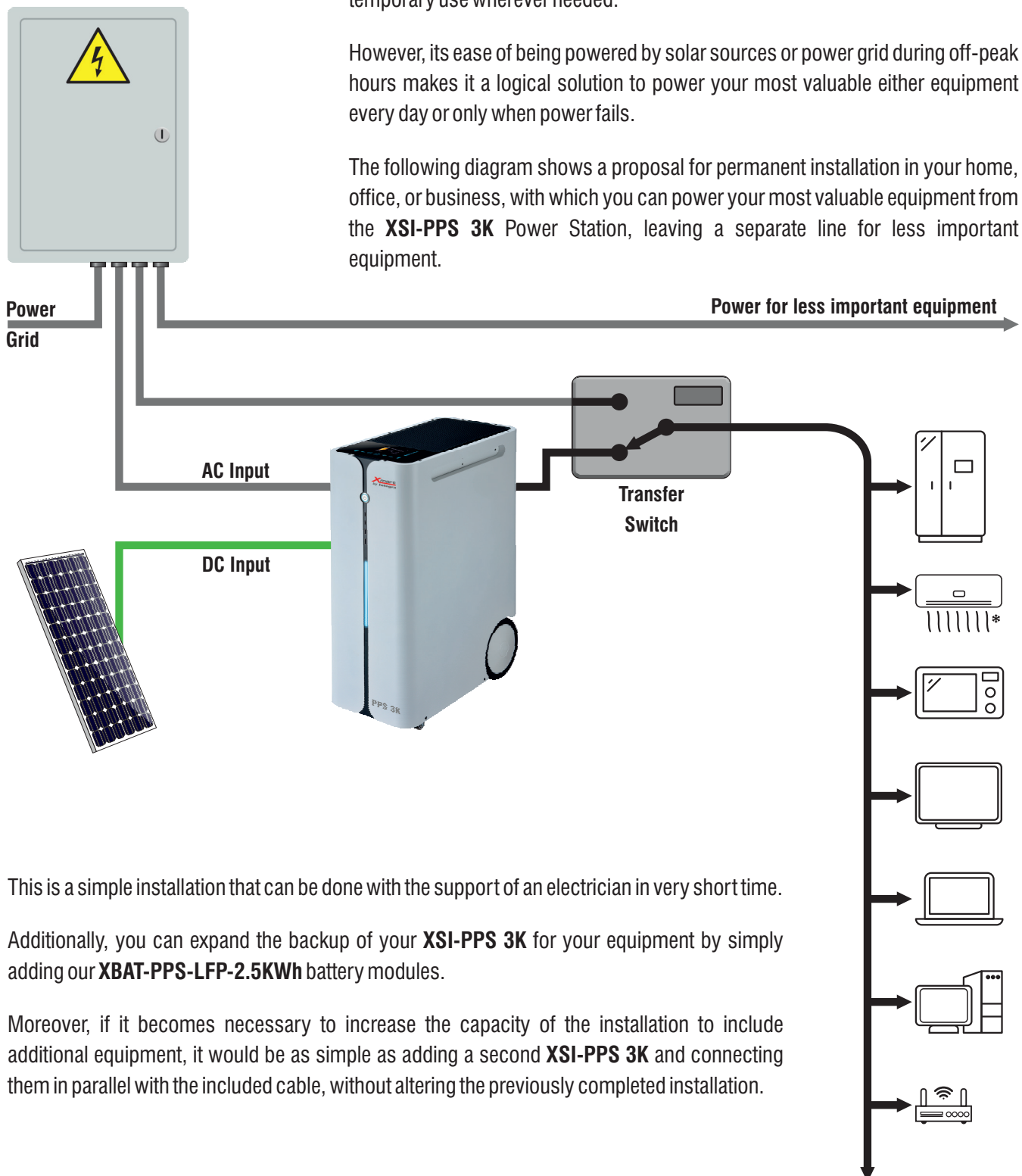

This is a simple installation that can be done with the support of an electrician in very short time.

Additionally, you can expand the backup of your **XSI-PPS 3K** for your equipment by simply adding our **XBAT-PPS-LFP-2.5KWh** battery modules.

Moreover, if it becomes necessary to increase the capacity of the installation to include additional equipment, it would be as simple as adding a second **XSI-PPS 3K** and connecting them in parallel with the included cable, without altering the previously completed installation.

The operation panel of our **XSI-PPS 3K** is located on the top panel of the device and consists of a color screen, a scroll bar, and 7 operational buttons. Our Power Stations can be monitored and configured from their modern LCD screens for optimal operation according to your requirements.

The LCD screen displays all relevant information for the device operation such as: Power flow diagram, Internal and external battery data (Voltage, Current, Capacity, Backup, Temperature, SOC), AC Input and Output (Voltage, Frequency, and Consumption), Solar Input (Voltage, Power, Current, Accumulated Generation), USB Chargers (On/Off), and Event Log.

Additionally, operational parameters can be configured, such as: AC Voltage and Frequency, Priority of Solar Energy and Grid use for both charging the batteries and powering the equipment connected to the XSI-PPS 3K, Battery charge and discharge data (Limit values, Currents, etc.), among others.

Moreover, control actions can be performed, such as turning the wireless connection on and off, adjusting the system date and time, etc.

## TOP VIEW



## TOP VIEW



The operation panel of our **XSI-PPS 1.2K/2.5K** is located on the top of the device and consists of an LCD, the power button, 3 indicator LEDs, and 4 operational buttons. These Power Stations can also be monitored and configured from their screens for optimal operation according to your requirements.

The LCD screen displays all the relevant information for the device operation, such as: Power flow diagram, Battery data (Voltage, Current, Power), AC Input and Output (Voltage, Frequency, and Consumption), Solar Input (Voltage, Current, Power).

Additionally, operational parameters can be configured, such as: AC Voltage and Frequency, Priority of Solar Energy and Grid use for both charging the batteries and powering the connected equipment, Battery charge and discharge data (Limit values, Currents, etc.), among others.

The indicator LEDs provide real-time information about the status of the device, its AC output, and its batteries.

All our Power Stations can be monitored, controlled, and configured from mobile devices using the **i.Solar** app.

**i.Solar** is available in both the Apple® and Google® app stores, allowing any smartphone running either IOS or Android to communicate with our Power Stations.

From **i.Solar**, you can monitor all the operational information of the devices, as if you were viewing their screens, and similarly, you can configure all their operational parameters with the convenience of your mobile device and from the palm of your hand.

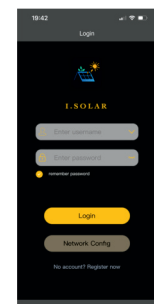

XSI-PPS - PORTABLE POWER STATION (1/2)	1.2K - 230V	2.5K - 230V
Out Capacity / Capacidad de Salida (VA)	1200 VA	2500 VA
Output Capacity / Capacidad de Salida (W)	1200 W	2500 W
<b>MAIN FEATURES / FUNCIONALIDADES</b>		
Built-in Charger / Cargador incorporado	MPPT	
AC-Solar Priority / Prioridad Solar-CA	Configurable by LCD - Display	
Parameters setting / Configuración de parámetros	by LCD - Display	
Anti-dust kit / Kit filtro anti polvo	Incluido	
Instalación	Portátil	
<b>AC INPUT / ENTRADA CA</b>		
Voltage / Tensión	230 VAC	
Input Range / Rango de entrada	Selectable / Seleccionable: Wide Range Mode: (90-280VAC) / UPS Mode: (170-280VAC)	
Max. AC Input Voltage / Máx. Voltaje de Entrada AC	300VAC	
Input frequency / Frecuencia de entrada	50Hz / 60Hz Auto sensing - (40Hz - 65Hz)	
AC Generator / Motogenerador C.A.	AC input compatible with generator / Entrada compatible con moto-generadores	
Phase / Fases	1 phase / 1 fase: 220/230/240 VAC (L-N)	
<b>OUTPUT / SALIDA</b>		
Output Voltage / Voltaje de Salida AC	220VAC, 230VAC, 240VAC (Configurable)	
Output Regulation / Regulación de Salida	+/- 5% (battery mode / modo batería)	
Output Frequency / Frecuencia de Salida AC	50Hz / 60Hz (Configurable)	
THDv	≤5% @ Linear Load / Carga Lineal ≤10% @ No Linear Load / Carga no Lineal	
Transfer Time / Tiempo AC a Inversor	10ms (UPS mode) / 20ms (Wide range mode)	
Waveform / Forma de Onda	Pure Sinewave / Sinusoidal Pura	
DC Offset	≤100mV	
Output Current / Corriente de Salida	6,8 A MAX.	14.2 A MAX.
<b>EFFICIENCY / EFICIENCIA</b>		
Inverter Efficiency / Eficiencia del inversor	93%	
Line mode Efficiency / Eficiencia modo línea	>95%	
No load consumption / Consumo interno sin carga	<35W	<50W
<b>OVERLOAD/ SOBRECARGA</b>		
Overload protection / Protección alto consumo	[<105%: OK] [105% to 130%: 10s] [>130%: 5s]	
Surge Power / Potencia Máxima	2.400 W (5s)	5.000 W (5s)
<b>PROTECTIONS</b>		
Short circuit Protection / Protección contra cortocircuitos	Line mode: Breaker / Battery mode: Electronic protection Modo Línea: Disyuntor / Modo Batería: Protección electrónica	
DC Reverse Polarity / Polaridad DC Invertida	Yes / Si	
Over-temperature / Sobre calentamiento	Yes / Si	
Input Current / Corriente de Entrada	Circuit Breaker / Disyuntor	
<b>BATTERIES / BATERIAS</b>		
Type / Tipo	A grade LiFePO4 Lithium-ion cell / LiFePO4, con Celdas de Iones de Litio Grado A	
Power / Potencia	768Wh	1536Wh
Rated Voltage / Tensión DC nominal	25,6 VDC	51,2 VDC
Full Charge Voltage / Voltaje a 100% de Recarga	28 VDC	56 VDC
Full Discharge Voltage / Voltaje a 100% de Descarga	20 VDC	40 VDC
Capacity / Capacidad	30AH	
Max. Continuous Discharge Current / Corriente Max. de Descarga Continua	60AH	
Max. Discharge Current / Corriente Max. de Descarga	65A	
Max. Charge Current / Corriente Max. de Recarga	30A (1C)	
Backup @ Full Load / Autonomía a plena carga	30 Min. Aprox.	
Lifecycle / Vida Útil	≥2500 cycles, 0.5C Charging/Discharging, ≥50%@EOL, 100% DoD / ≥2500 Ciclos, Carga/Descarga a 0.5C, EOL ≥50%, DoD 100%	
Protection / Protección	BMS	
<b>USB OUTPUTS / SALIDAS USB</b>		
USB Type-A Output / Salida USB Tipo A	2 * 18W - PD 3.0 - 5V/3A , 9V/2A	
USB Type-C Output / Salida USB Tipo C	2 * 65W - PD 3.0 - 5V/3A , 9V/2A , 20V/3.25A	
Wireless Max. Charging Power / Potencia Máxima de Carga Inalámbrica	15W	

XSI-PPS - PORTABLE POWER STATION (2/2)	1.2K - 230V	2.5K - 230V
<b>USER INTERFACE / INTERFAZ CON EL USUARIO</b>		
LED	Output Power Source, Battery Status, Fault or Warning Status / Fuente de Alimentación de Salida, Estado de las Baterías, Estado de Falla o Alarma	
LCD	AC&PV Inputs, Output, Load (%), Battery level, Charging status (%), Operation mode, etc Valores de entrada AC y Solar, Salida, Consumo, Batería, Cargador, Modo de operación, etc	
<b>ALARM / ALARMAS</b>		
Acoustic Alarm / Alarma Sonora	Beep alarm is activated to warn about alarms / Alarma sonora para anunciar alarmas	
Alarm Codes / Mensajes de Alarma	Alarm & fault codes are displayed on LCD / Mensajes de alarma y error mostrados en el LCD	
<b>CHARGERS (SOLAR &amp; AC)</b>		
Solar charger type / Cargador solar	MPPT	
Charging process / Proceso de recarga	Smart Specific for LiFePO4 Batteries / Inteligente, Especifico para Baterías de LiFePO4	
Nominal PV Voltage / Voltaje PV Nominal	240VDC	
PV Start-up Voltage / Voltaje PV Mínimo	70VDC +/- 10Vdc	
Max. PV Power / Potencia Max. Entrada PV	2.000 W	3.000W
Max. PV VOC / Voltaje en abierto paneles (VOC)	350 VDC	450 VDC
PV Array MPPT Range / Rango MPPT	60 to 300 VDC	60 to 400 VDC
Solar charger Amps / Corriente cargador solar	10 A MAX.	
AC charger Amps / Corriente cargador CA	30 A MAX. (@ Vin:230VAC)	
Total charging Amps / Total corriente cargador	30 A MAX. (@ Vin:230VAC)	
Efficiency / Eficiencia	98% MAX	
<b>CONNECTIONS / CONEXIONES</b>		
AC Main / Entrada CA (L-N-G)	IEC 10A 250V C14	
AC Output / Salida CA (L-N-G)	Schuko (CEE 7/4), Universal (Optional)	
Solar Panel Input / Entrada Panel Solar (+) & (-)	MC4 Connector	
<b>PHYSICAL / FISICAS</b>		
DxWxH / Prof.*Ancho*Altura (cm)	45 x 28 x 36,8	
Packing DxWxH / Empaque Prof.*Ancho*Alto (cm)	57,5 x 38 x 44,5	
Net Weight / Peso Neto (kgs)	20.5	25.5
Gross Weight / Peso Bruto (kgs)	24.5	29.5
<b>OPERATIONAL CONDITIONS / CONDICIONES DE OPERACIÓN</b>		
Ingress Protection IP / Grado de Protección IP	IP20 (Indoor / Para Uso Interior)	
Rel. Humidity / Humedad Relativa	< 95 % RH (non-condensing / no condensante)	
Operating Temperature / Temperatura Operación	-10 to 50 °C	
Storage Temperature / Temperatura Almacenaje	-15 to 60 °C	
Audible Noise / Ruido Audible	<60dB	
Max. Altitude / Altura de Operación Max.	4.500 meters above sea level, Capacity Derrate 1% each 100 mt (Over 1.500 m) / 4.500 msnm, Disminución de Capacidad de 1% cada 100m (sobre 1.500m)	
<b>COMMUNICATION / COMUNICACION</b>		
USB	Built-in / Incorporado	
RS232	Built-in / Incorporado	
WIFI	Built-in, Setting & Monitoring via App / Incorporado. Supervisión y Configuración via App	
<b>SAFETY &amp; STANDARDS / NORMATIVAS Y ESTANDARES</b>		
CE	CE Compliant	
EMC Domestic, Commerce & Small Industries / EMC Doméstica, Comercio y PYME	EN 61000-6-1	
EMC at Industries / EMC en Industria	EN-61000-6-2	
EM Emissions Domestic, Commerce & Small Ind. / Emisiones EM Domésticas, Comercio y PYME	EN 61000-6-3	
EME at Industries / EME en Industria	EN 61000-6-4	
Safety AC Inverters / Seguridad para Inversores AC	IEC/EN 62109-1/2	
Safety Li-Ion Batt. / Seguridad para Baterías de Li-Ion	IEC 62619	
Li-Ion Batt. Transport / Transporte de Bat. De Li-Ion	UN38.3	
Quality and Environment	RoHS / ISO9001 & ISO14001	

Technical specifications can be modified to comply with special requirements / Las especificaciones pueden, bajo requerimiento, adaptarse a proyectos especiales  
 Technical specifications may change without further notice / Por motivos comerciales o técnicos las especificaciones pueden cambiar sin previo aviso.



Otras marcas y logos son propiedad de sus respectivos dueños. Certificaciones aplican de acuerdo al mercado destino y modelo del producto

XSI-PPS - PORTABLE POWER STATION (1/2)	3K-120V	3K-230V
Output Cap. / Cap. de Salida (VA / W)	3000 VA / 3000W	3000 VA / 3000W
<b>MAIN FEATURES / FUNCIONALIDADES</b>		
Built-in Charger / Cargador incorporado	MPPT	
AC-Solar Priority / Prioridad Solar-CA	Configurable by LCD - Display	
Parameters setting / Configuración de parámetros	by LCD - Display	
Anti-dust kit / Kit filtro anti polvo	Incluido	
Instalación	Portátil	
<b>AC INPUT / ENTRADA CA</b>		
Voltage / Tensión	100 / 110 / 120 VAC	220 / 230 / 240 VAC
Input Range / Rango de entrada (VAC)	Wide Range: 80 - 140 ; UPS Mode: 85 - 130	Wide Range: 90 - 280 ; UPS Mode: 170 - 280
Input frequency / Frecuencia de entrada	50Hz / 60Hz Auto sensing - (40Hz - 65Hz)	
AC Generator / Motogenerador C.A.	AC input compatible with generator / Entrada compatible con moto-generadores	
Phase / Fases	1 phase / 1 fase	
<b>OUTPUT / SALIDA</b>		
Output Voltage / Voltaje de Salida AC	100 / 110 / 120 VAC (Configurable)	220 / 230 / 240 VAC (Configurable)
Output Regulation / Regulación de Salida	+/- 5% (battery mode / modo batería)	
Output Frequency / Frecuencia de Salida AC	50Hz / 60Hz (Configurable)	
THDv	≤5% @ Linear Load / Carga Lineal ; ≤10% @ No Linear Load / Carga no Lineal	
Transfer Time / Tiempo AC a Inversor	15ms - 20ms	
Waveform / Forma de Onda	Pure Sinewave / Sinusoidal Pura	
DC Offset	≤100mV	
Output Current / Corriente de Salida	17 A MAX.	33 A MAX.
<b>EFFICIENCY / EFICIENCIA</b>		
Inverter Efficiency / Eficiencia del inversor	93%	
No load consumption / Consumo interno sin carga	<30W	
<b>OVERLOAD/ SOBRECARGA</b>		
Overload protection / Protección alto consumo	[<105%: OK] [105% to 130%: 10s] [>130%: 5s]	
Surge Power / Potencia Máxima	6.000 W (5s)	
<b>PROTECTIONS</b>		
Short circuit Protection / Protección cortos	Line mode: Breaker / Battery mode: Electronic protection Modo Línea: Disyuntor / Modo Batería: Protección electrónica	
Over-temperature / Sobrecalentamiento	Yes / Si	
Input Current / Corriente de Entrada	Circuit Breaker / Disyuntor	
<b>BATTERIES / BATERIAS</b>		
Type / Tipo	A grade LiFePO4 Lithium-ion cell / LiFePO4, con Celdas de Iones de Litio Grado A	
Power / Potencia	2560W	
Rated Voltage / Tensión DC nominal	25,6 VDC	
Full Charge Voltage / Voltaje a 100% de Recarga	28,2 VDC	
Full Discharge Voltage / Voltaje a 100% de Descarga	20 VDC	
Capacity / Capacidad	100AH	
Imax Continuous Discharge / IMax. Descarga Continua	120AH	
Max. Discharge Current / Corriente Max. de Descarga	200A	
Max. Charge Current / Corriente Max. de Recarga	100A (1C)	
Lifecycle / Vida Útil	≥3500 cycles, 0.5C Charging/Discharging, ≥80%@EOL, 100% DoD / ≥3500 Ciclos, Carga/Descarga a 0.5C, EOL ≥80%, DoD 100%	
Protection / Protección	BMS	
<b>USB OUTPUTS / SALIDAS USB</b>		
USB Type-A Output / Salida USB Tipo A	2 * 18W - PD 3.0 - 5V/3A , 9V/2A	
USB Type-C Output / Salida USB Tipo C	2 * 65W - PD 3.0 - 5V/3A , 9V/2A , 20V/3.25A	
<b>USER INTERFACE / INTERFAZ CON EL USUARIO</b>		
RGB Status Indicator / Indicador de Estado RGB	Battery Capacity & Operation Status / Capacidad de las Baterías, Modo de Operación	
LCD	AC&PV Inputs, Output, Load (%), Battery level, Charging status (%), Operation mode, etc Valores de entrada AC y Solar, Salida, Consumo, Batería, Cargador, Modo de operación, etc	
<b>ALARM / ALARMAS</b>		
Acoustic Alarm / Alarma Sonora	Beep alarm is activated to warn about alarms / Alarma sonora para anunciar alarmas	
Alarm Codes / Mensajes de Alarma	Alarm & fault codes are displayed on LCD / Mensajes de alarma y error mostrados en el LCD	

XSI-PPS - PORTABLE POWER STATION (2/2)	3K-120V	3K-230V
<b>CHARGERS (SOLAR &amp; AC)</b>		
Solar charger type / Cargador solar	MPPT	
Charging process / Proceso de recarga	Smart Specific for LiFePO4 Batteries / Inteligente, Especifico para Baterías de LiFePO4	
Nominal PV Voltage / Voltaje PV Nominal	230VDC	
PV Start-up Voltage / Voltaje PV Mínimo	70VDC +/- 10Vdc	
Max. PV Power / Potencia Max. Entrada PV	3.000W	
Max. PV VOC / Voltaje en abierto paneles (VOC)	450VDC	
PV Array MPPT Range / Rango MPPT	60 to 400 VDC	
Solar charger Amps / Corriente cargador solar	100 A MAX.	
AC charger Amps / Corriente cargador CA	50 A MAX.	
Total charging Amps / Total corriente cargador	100 A MAX.	
<b>CONNECTIONS / CONEXIONES</b>		
AC Main / Entrada CA (L-N-G)	Terminal Block / Regleta	IEC 15A 250V C14
AC Output / Salida CA (L-N-G)	Schuko (CEE 7/4), Universal (Optional)	
Battery Input / Entrada de Baterías (+) & (-)	Dedicated Connector / Conector Dedicado	
Solar Panel Input / Entrada Panel Solar (+) & (-)	MC4 Connector	
<b>PHYSICAL / FISICAS</b>		
DxWxH / Prof.*Ancho*Altura (cm)	45 x 22,2 x 60	
Packing DxWxH / Empaque Prof.*Ancho*Alto (cm)	56,7 x 35,8 x 76	
Net Weight / Peso Neto (kgs)	42	
Gross Weight / Peso Bruto (kgs)	47	
<b>OPERATIONAL CONDITIONS / CONDICIONES DE OPERACION</b>		
Ingress Protection IP / Grado de Protección IP	IP20 (Indoor / Para Uso Interior)	
Rel. Humidity / Humedad Relativa	< 90 % RH (non-condensing / no condensante)	
Temperature / Temperatura	Operating / Operación: -15 to 50 °C - Storage / Almacenamiento: -0 to 50 °C	
Audible Noise / Ruido Audible	<50dB	
Max. Altitude / Altura de Operación Max.	4.500 meters above sea level, Capacity Derrate 1% each 100 mt (Over 1.500 m) / 4.500 msnm, Disminución de Capacidad de 1% cada 100m (sobre 1.500m)	
<b>COMMUNICATION / COMUNICACION</b>		
Built-in / Incorporado	USB, WIFI (Setting & Monitoring via App / Incorporado. Supervisión y Configuración via App)	
<b>SAFETY &amp; STANDARDS / NORMATIVAS Y ESTANDARES</b>		
CE	CE Compliant	
EMC, EME, & Safety / EMC, EME y Seguridad	EN 61000-6-1, EN-61000-6-2, EN 61000-6-3, EN 61000-6-4, IEC/EN 62109-1, IEC/EN 62109-2	
Safety Li-Ion Batt. / Seguridad para Baterías de Li-Ion	IEC 62619	
Li-Ion Batt. Transport / Transporte de Bat. De Li-Ion	UN38.3	
Quality and Enviroment	RoHS / ISO9001 & ISO14001	

LFP - PORTABLE LiFePO4 BATTERY PACK	2.5KWh
Power / Capacidad	2560Wh
<b>PARAMETERS / PARAMETROS</b>	
Nominal Voltage / Voltaje Nominal	25.6VDC
Typical Capacity / Capacidad Típica	100 Ah
Rated Discharging Current	120 A
<b>PHYSICAL / FISICAS</b>	
DxWxH / Prof.*Ancho*Altura (cm)	45 x 15 x 62,2 cm
Net Weight / Peso Neto (kgs)	33
<b>SAFETY &amp; STANDARDS / NORMATIVAS Y ESTANDARES</b>	
Safety Li-Ion Batt. / Seguridad para Baterías de Li-Ion	IEC 62619
Li-Ion Batt. Transport / Transporte de Bat. De Li-Ion	UN38.3
Quality and Enviroment	RoHS / ISO9001 & ISO14001

**XBAT-PPS-LFP-2.5KWh**



Technical specifications can be modified to comply with special requirements / Las especificaciones pueden, bajo requerimiento, adaptarse a proyectos especiales  
 Technical specifications may change without further notice / Por motivos comerciales o técnicos las especificaciones pueden cambiar sin previo aviso.



Other marks and logos are property of their respective owners. Certifications apply according to the market destination and model of the product.

## LiFePO4 BATTERY

# XBAT-PPS-LFP-2.5KWh

Portable LFP battery, developed to enlarge backup time for XSI-PPS-3K, with a built-in smart BMS capable of controlling all internal cell's data, as well as balancing their charging/discharging processes to increase battery lifespan.



### Modern and Reliable Technology:

This 25.6VDC LFP battery can supply up to 100Ah (Max. capacity: 2560Wh) and it is designed specifically to enlarge the backup capacity of XSI-PPS-3K in indoors and outdoors applications.

A robust, transportable, and microprocessor-based design makes this battery module a perfect solution for domestic, commercial, and office environments. Cutting-edge technology at your disposal.

### Built-in BMS:

Each battery includes an internal BMS to protect it from over-discharge, high temperature, over-charge, and over-current, for a safe and reliable operation.

### Robust Design:

This is a 100% maintenance-free battery able to operate during long time from 0 °C up to +50 °C and manage over 3500 charge/discharge cycles (100% DOD & 80% EOL @25 °C. 0.5C/0.5C). Includes UN38.3 and CE certification.

### Parallel Operation:

Up to 2 units can be connected in parallel to enlarge the battery capacity of XSI-PPS-3K up to 7.5KWh.

Moreover, if 2 XSI-PPS-3K are connected in parallel, the battery capacity can rise up to 15KWh.

### Intuitive Indicator System:

A smart set of LEDs indicate the battery operation status at all times.

- SOC LEDs: Indicate the battery Status Of Charge in segments of 14% aprox.
- RUN LED: Indicates when the battery is On and BMS communication.
- ALARM: Indicates battery faults and battery deep discharges.

### Additional features:

- This is a non-toxic, non-polluting, and environmentally friendly product.
- Includes grade A LiFePO4 batteries.
- Safety performance and long lifespan.
- No installation required and easily portable, ideal for outdoor adventures.
- Monitoring, control, and configuration via Smartphone App, when connected to XSI-PPS-3K.



**Applications: Backup for appliances indoor/outdoor Household Appliances, Office and Commercial Equipment, Campings, etc.**



LiFePO4 BATTERY

**Xmart**  
by **Integra**

# XBAT-PPS-LFP-2.5KWh



XSI-PPS-3K +  
XBAT-PPS-LFP-2.5KWh  
Capacity: 5KWh



XSI-PPS-3K +  
2 XBAT-PPS-LFP-2.5KWh  
Capacity: 7.5KWh

1 or 2 **XBAT-PPS-LFP-2.5KWh** can be connected to an **XSI-PPS-3K** to expand its backup capacity from 2.5KWh to 5KWh or 7.5KWh, respectively.

A modern BMS (Battery Management System), allows an efficient and safe management of all batteries, including daily discharges over the long life that distinguishes LFP batteries from standard VRLA ones.

**XBAT-PPS-LFP-2.5KWh** can be connected to **XSI-PPS-3K** operating in parallel to increase autonomy. This can be done even if the number of external batteries for each **XSI-PPS-3K** is different. Maximum achievable battery capacity is 15KWh, when 2 batteries are connected to each **XSI-PPS-3K**.



## Technical Features / Características Técnicas

XBAT-PPS-LFP - PORTABLE BATTERY PACK	2.5KWh
Power / Capacidad	2560Wh
<b>PARAMETERS / PARAMETROS</b>	
Nominal Voltage / Voltaje Nominal	25.6VDC
Typical Capacity / Capacidad Típica	100 Ah
Max. Discharge Current / Máx. Corriente de Descarga	200 A
Max. Charge Current / Máx. Corriente de Carga	100 A
Full Charge Voltage	28.2 VDC
Full Discharge Voltage	22.0 VDC
Lifecycle	≥3500 cycles, 0.5C charging/discharging ≥80% @EOL 100% DoD
Protection	BMS, Breaker
<b>PHYSICAL / FISICAS</b>	
IP Rating / Grado de Protección IP	IP20 (Indoor / Para Uso Interior)
DxWxH / Prof.*Ancho*Altura (cm)	42 x 18.5 x 54 cm
Net Weight / Peso Neto (kgs)	24.5
Communication / Comunicación	RS485 (RJ45), ID switch
Inner Resistance / Resistencia Interna	≤0.6 mohm
Indicators LEDs/ LEDs Indicadores	LED (SOC, Run, Alarm)
Operation Temperature / Temperatura de Operación	0 to 50 °C
Storage Temperature / Temperatura de Almacenamiento	-15 °C to 50 °C
<b>SAFETY &amp; STANDARDS / NORMATIVAS Y ESTANDARES</b>	
Safety Li-Ion Batt. / Seguridad para Baterías de Li-Ion	IEC 62619
Li-Ion Batt. Transport / Transporte de Bat. De Li-Ion	UN38.3
Quality and Environment / Calidad y Ambiente	RoHS / ISO9001 & ISO14001

## Solar Charger

# XSI CHARGER MPPT 300W/600W

Solar charger for 12VDC or 24VDC Battery Banks, with MPPT technology (Maximum Power Point Tracking) for best use of maximum available power from solar panels. Offers a wide range in solar input to adapt to different panel types and arrays and DC Output to power DC loads directly. Perfect solution to power DC equipment with long backup.

### Features

- Microprocessors design
- MPPT Technology
- Available capacities: 300W & 600W
- Wide DC Input range
- 12VDC & 24VDC output models
- Smart and efficient LED Status indicator system
- All operation parameters in a smart LCD: Solar Input, Battery Type, Load, Battery Voltage, battery Capacity, Charging Current.
- Compatible with several battery types:
  - Vented Batteries
  - Sealed Batteries (VRLA-AGM)
  - GEL Batteries
  - Ni-Cd Batteries
  - User Defined. Setting recharge voltages (Bulk and Floating)
- Wall Mount



High Efficiency DC Output



Supports Multiple Batt. Types



2 years warranty

### Operation Diagram

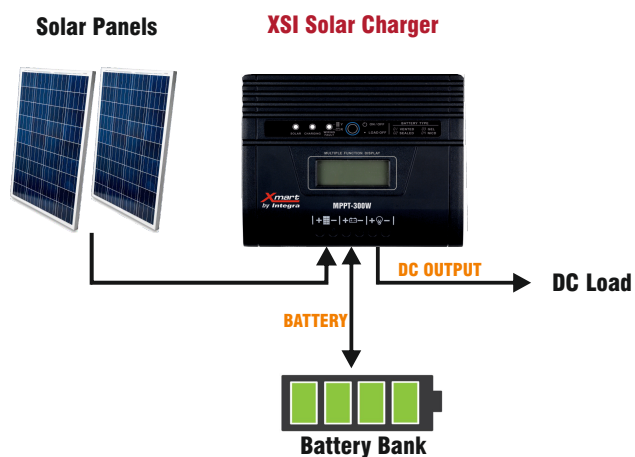

## Parts Identification / Identificación de Partes

1. LCD
2. ON/OFF Switch / Interruptor ON/OFF
3. Wiring Fault LED / LED de Falla de Cableado
4. Charging LED / LED de Recarga
5. Solar Input LED / LED de Entrada Solar
6. Solar Input Terminals / Terminales de Entrada Solar
7. Battery Terminals / Terminales de Baterías
8. DC Load Terminals / Terminales de Salida DC

### Rear Panel

#### XSI CHARGER MPPT 300W



#### XSI CHARGER MPPT 600W



## Technical Specifications / Características Técnicas

XSI-CHGR-300W / 600W	MPPT 300W	MPPT 600W
Capacity / Capacidad	300W	600W
<b>Input / Entrada</b>		
MPPT Range / Rango MPPT	(15V - 37V)	(15V - 37V) @ 12VDC BAT. VOLT. (30V - 66V) @ 24VDC BAT. VOLT.
Max. Open Circuit V / V Max. En Abierto (Voc)	50V	(50V) @ 12VDC BAT. VOLT. (75V) @ 24VDC BAT. VOLT.
Max. Input Current / Corriente Max.	18A	18A
<b>Output / Salida</b>		
Nominal Battery Voltage / Voltaje de Baterías	12V	12V / 24V (autosensing)
Max. Charging Current / Corriente Max. Recarga	12.5A	25A
Standby Consumption / Consumo en standby	2W	2W
<b>Batteries / Baterías</b>		
Battery Type / Tipos de batería	Vented / VRLA-AGM / AGM / Ni-Cd / Custom	
Recharging Voltage / Voltaje de Recarga	Bulk / Floating	
- Vented / Baterías ventiladas:	14.3 / 13.2 V	
- VRLA-AGM:	14.3 / 13.4 V	
- GEL	14.3 / 13.7 V	
- Ni-Cd	14.3 / 14.0V	
<b>LEDs-Indications / Indicaciones LEDs</b>		
Solar Input Reversal / Entrada Solar Invertida	LED: Yellow / Amarillo (ON)	
Battery Input Reversal / Baterías invertidas	LED: Red / Rojo (ON)	
Solar & Batt reversal / Entrada solar y baterías invertidas	LED: Orange / Naranja	
<b>Dimensions-Weight / Características Físicas</b>		
Dimension / Tamaño	13.5*17.0*5.8 cm	22.0*17.0*5.8 cm
Weight / Peso	0.9 Kg	1.85 Kg
<b>Environment / Condiciones de Operación</b>		
Humidity / Humedad	0 - 100% RH (Non condensing)	
Operating Temperature / Temp. Operación	- 20°C to 55°C	
Storage Temp / Temp. Almacenaje	- 40°C to 75°C	
<b>Safety &amp; Standards / Normativas y Estándares</b>		
Household and similar appliances – Safety part 1 / Electrodomésticos y similares - Seguridad parte 1	EN 60335-1 (General Requirements / Requerimientos Generales)	
Household and similar appliances – Safety part 2-29 / Electrodomésticos y similares - Seguridad parte 2-29	EN 60335-1-29 (Particular Requirements for Batt. Chargers / Requerimientos particulares para cargadores de baterías)	
Emissions Standards / Estándares para emisiones	EN 61000-6-3 (for residential, commercial & light-industrial env. / para instalaciones domésticas, comerciales y PYME)	
Immunity Standards / Estándares para Inmunidad	EN 61000-6-2 (for residential, commercial & light-industrial env. / para instalaciones domésticas, comerciales y PYME)	
Degree of protection / Grado de Protección	IP20	
Quality and Environment	RoHS / ISO9001 & ISO14001	



Brands and Logos belong to their respective owners. Certifications may apply according to product model and destination country.  
Las marcas y logos pertenecen a sus respectivos propietarios. Algunas certificaciones pueden aplicar dependiendo del modelo de producto y el país destino.

## Solar Charger

# XSI CHARGER MPPT 3KW60

Solar charger for 12VDC or 24VDC Battery Banks, with MPPT technology (Maximum Power Point Tracking) for best use of maximum available power from solar panels. Offers a wide range in solar input to adapt to different panel types and arrays.

## Features



- Microprocessors design
- MPPT Technology
- Capacity 3000W / 60A
- Parallel operation to manage big battery banks
- Wide DC Input range
- DC Output: 12V, 24V, & 48V (Automatic Selection)
- Smart and efficient LCD Status indicator system
- All operation parameters in a smart LCD: Solar Input, Battery Type, Load, Battery Voltage, battery Capacity, Charging Current.
- Supports
  - Sealed Batteries (VRLA-AGM)
  - GEL Batteries
  - User Defined. Setting recharge voltages (Bulk and Floating)
- Several communication options (RS232, USB, Rs485, SNMP) and monitor/control software
- 3 stages smart battery charger, including temperature compensation
- Battery equalization feature
- Wall Mount



Automatic DC Output



Supports Multiple Batt. Types



2 years warranty

## Operation Diagram

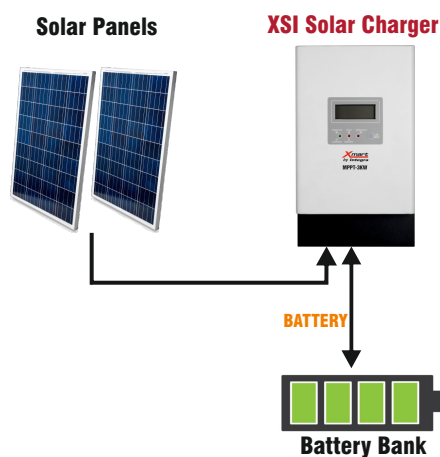

## Parts Identification / Identificación de Partes

1. LCD
2. LED: Power ON / Charging (Encendido / Cargando)
3. LED: Fault / Warning (Falla / Alarma)
4. LED: Wiring Fault (Falla de Cableado)
5. Push Button: ON / Menu (Pulsador: Encendido / Menú)
6. Terminals: Solar Input (Terminales: Entrada Solar)
7. Terminals: Battery Output (Terminales: Salida Baterías)
8. Terminals: Remote Temp. Sensor (Sensores de Temp. Remotos)
9. Terminals: Batt. Voltage Sensor (Terminales: Sensor Voltaje Bat.)
10. Cover (Cubierta)
11. RS232 Port (Puerto RS232)
12. Smart Port (Puerto Inteligente para tarjetas de comunicación)
13. Ground Terminal (Terminal de Tierra)

## Rear Panel / Panel Trasero

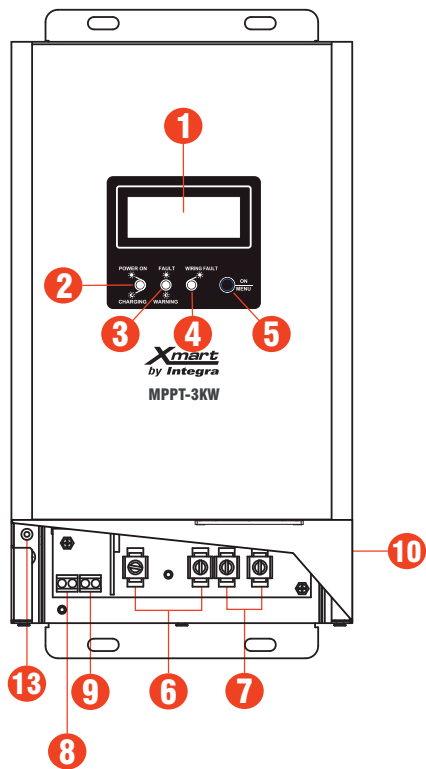

### Vista Inferior

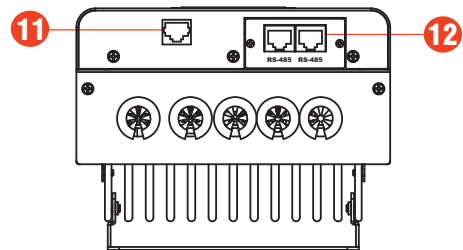

## Technical Specifications / Características Técnicas

XSI-CHGR-3KW60	MPPT 3KW60
Capacity / Capacidad	3.000W
<b>Input / Entrada</b>	
MPPT Range / Rango MPPT	(60V - 115V)
Max. Open Circuit V / V Max. En Abierto (Voc)	145V
Max. Input Current / Corriente Max.	60A
<b>Output / Salida</b>	
Nominal Battery Voltage / Voltaje de Baterías	12V / 24 / 48V (Auto)
Max. Charging Current / Corriente Max. Recarga	60A
<b>Batteries / Baterías</b>	
Battery Type / Tipos de batería	VRLA-GEL / Flooded / Custom
Recharging Voltage per batt. / Voltaje de Recarga por batería	Bulk / Floating
- VRLA-AGM-GEL:	14.1 / 13.5 V
- Flooded	14.6 / 13.5 V
- Custom	Config. / Config.
<b>LEDs-Indications / Indicaciones LEDs</b>	
	Green LED / LED Verde:
	ON = Charger ON / Encendido = Cargador Encendido
Power On / Charging // Encendido/Cargando	Blinking every 0.5s = Constant current stage / Etapa de corriente constante (Bulk)
	Blinking every 1s = Constant voltage stage / Etapa de voltaje constante (Absorption)
	Blinking every 5s = Floating stage / Etapa Flotante (Floating)
	Blinking every 3s = Battery equalizing / Ecualizando baterías
	Red LED / LED Rojo:
	ON = Fault / Encendido = Falla
Fault / Warning // Falla/Alarma	On Blinkng = Warning / Encendido intermitente = Alarma
	Red LED: On = Wrong battery connection polarity
Wiring Fault // Falla de Cableado	LED Rojo: Encendido = Polaridad incorrecta en conexión de baterías
<b>Dimensions-Weight / Características Físicas</b>	
Dimensions / Medidas	13.5*16.5*13.0 cm
Weight / Peso	4.5 Kg
<b>Environment / Condiciones de Operación</b>	
Humidity / Humedad	0 - 90% RH (Non condensing)
Operating Temperature / Temp. Operación	- 0°C to 55°C
Storage Temp / Temp. Almacenaje	- 40°C to 75°C
<b>Safety &amp; Standards / Normativas y Estándares</b>	
Household and similar appliances – Safety part 1 / Electrodomésticos y similares - Seguridad parte 1	EN 60335-1 (General Requirements / Requerimientos Generales)
Household and similar appliances – Safety part 2-29 / Electrodomésticos y similares - Seguridad parte 2-29	EN 60335-1-29 (Particular Requirements for Batt. Chargers / Requerimientos particulares para cargadores de baterías)
Emissions Standards / Estándares para emisiones	EN 61000-6-3 (for residential, commercial & light-industrial env. / para instalaciones domésticas, comerciales y PYME)
Immunity Standards / Estándares para Inmunidad	EN 61000-6-2 (for residential, commercial & light-industrial env. / para instalaciones domésticas, comerciales y PYME)
Degree of protection / Grado de Protección	IP31 (para interiores)
Quality and Environment	RoHS / ISO9001 & ISO14001

### Recharge Curve / Curva de Recarga

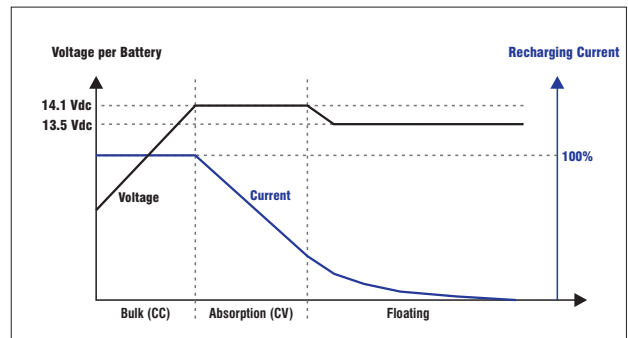

XSI-MPP-CHGR (P3)



Brands and Logos belong to their respective owners. Certifications may apply according to product model and destination country. Las marcas y logos pertenecen a sus respectivos propietarios. Algunas certificaciones pueden aplicar dependiendo del modelo de producto y el país destino.

## XMA SOLAR PANEL

# XPV-055-20M

## Monocrystalline PV Solar Panel

### Monocrystal Solar Panel

**55W / 36 cells / 20V**

High efficiency solar cells (3x12 = 36 Cells).  
High performance with low light conditions.  
For severe environmental conditions.  
Manufactured with high quality components.

**MONO**  
**55W**

High Efficiency Monocrystal

**VMP**  
**20**

Voltage at Maximum Power

**36**

Cells in Series: 3x12 (166\*41.5mm)

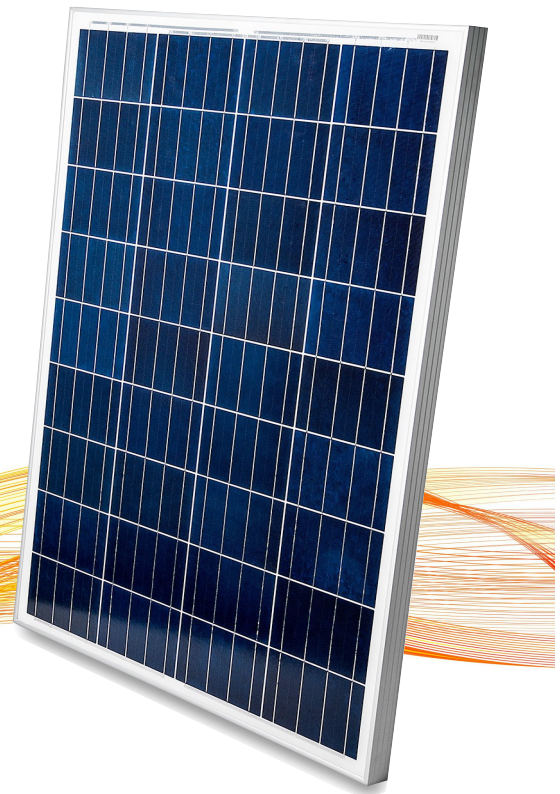

### Outstandings Features

**5**

#### 5 Layers lamination

(1) Low-Iron Tempered Glass+ (2) EVA +  
(3) PV Cells + (4) EVA + (5) Backsheet

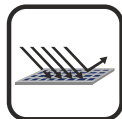

#### High Transmission Tempered Glass:

Minimal sun light reflection guaranteed

**AI**

#### Anodized Aluminum Frame:

Corrosion-resistance and structural strength



#### Connection:

Junction box IP65

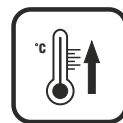

#### High temperature resistant:

Operation Range: -40 to +85°C

**80%**  
**25**  
**YEARS**

#### Guaranteed Output Power 80%:

During first 25 years

**90%**  
**10**  
**YEARS**

#### Guaranteed Output Power 90%:

During first 10 years

**Product**  
**5**  
**YEARS**

#### Product Warranty

5 years on materials and assembly

**Technical Features / Características Técnicas** **XPV SOLAR PANEL**

# XPV-055-20M

## Electric Specifications (STC\*)

Peak power / Potencia máxima (Pmax)	55W
Cell efficiency / Eficiencia	18.03%
Max. power voltage / Voltaje a potencia max. (Vmp)	20.92V
Max. power current / Corriente a potencia max.	2.63A
Open circuit voltage / Voltaje en abierto (Voc)	24.46V
Short circuit current / Corriente de corto circuito (Isc)	2.75A
Power tolerance / Tolerancia de potencia	3%
Max. system voltage / Voltaje max. del sistema	600V
Max. Overcurrent / Sobrecorriente Máxima	15A
Qty. bypass diodes / Cantidad de diodos de bypass	2 x 12A bypass diodes

(\* Irradiance: 1000W/m<sup>2</sup> / AM1.5G, Module T: 25°C

## Temperature Characteristics

Nominal Operating Temperature / Temp. de operación	42 +/- 2°C
Operating range / Rango de operación	-40 to 85°C
Isc coefficient / Coeficiente (a_Isc)	0.046%/°C
Voc coefficient / Coeficiente Temp (b_Voc)	-0.26%/°C
Pmax coefficient / Coeficiente (g_Pmax).	-0.32%/°C

## Connections

Junction Box / Caja de conexiones	Without Cables: IP-65 / With Cables: IP68
Connectors / Conectores	MC4 compatible
Cables	Optional: MC4 / 4mm (60cm)

## Mechanical Specifications

Dimensions / Tamaño	535*570*25mm
Weight / Peso	3.2Kg
Max. Wind Load / Carga máxima por viento	2400 Pa
Snow Load / Carga por Nieve	5400 Pa
Application Class / Clase Aplicación	Class A
Fire Rating / Clasificación Fuego	Class C
Solar Cells Arrangement / Cantidad de celdas	36 in series (3*12) - Cell Type: Mono 166*41.5mm (1/4)
Panel Construcción / Estructura del Panel	5 layers
Tempered Glass / Cristal Templado (EN 1096-4:2004)	High transmission, low-iron Solar Glass / Cristal Solar Anti reflectivo de bajo-hierro (3.2mm)
Backsheet / Laminado trasero (Toyol - TUV)	QPL High Reflectance Anti-UV long lifetime / QPL reflectante / Anti-UV / de larga vida (0.25mm)
EVA: Ethylene Vinyl Acetate (First - UL)	High light transmission + High UV Block / De alta transmisión de luz + alto bloqueo UV (0.45mm)
Solar Cells / Celdas solares (Taiwan # 1 Manufacturer)	"A" grade manufactured in Taiwan / Grado "A" fabricada en Taiwan
Junction Box / Caja de Conexión	IP65 (CE)
Frame / Marco	High corrosion resistance anodized aluminium / Aluminio anodizado resistente a corrosión

## Current (A) vs Voltage (V)

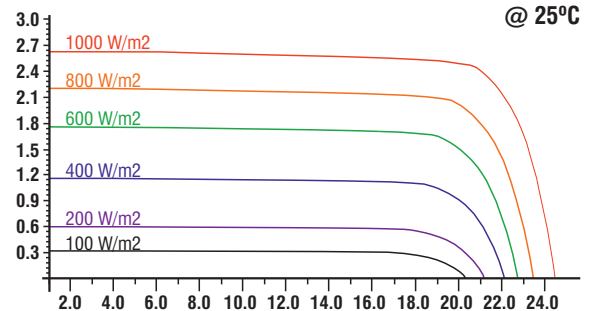

## Output Power vs Years of Operation

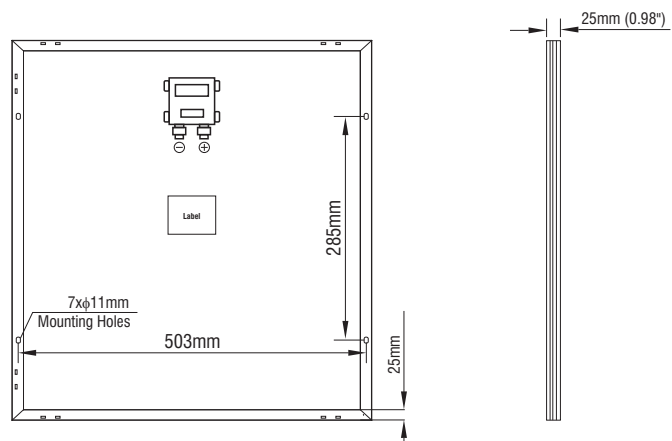
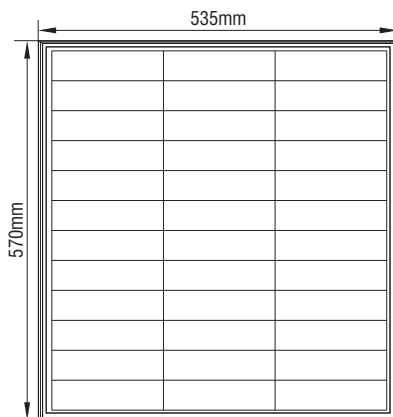
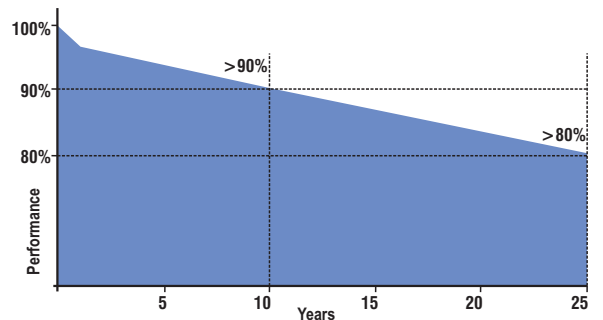

## XMA SOLAR PANEL

### XPV-080-18VP

### Polycrystalline PV Solar Panel

#### Polycrystal Solar Panel

**80W / 36 cells in series / 18V**

High efficiency solar cells

High performance with low light conditions.

For severe environmental conditions.

Manufactured with high quality components.



High Efficiency Polycrystal



Voltage at Maximum Power



Cells in Series



#### Outstandings Features

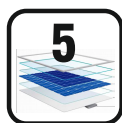

**5 Layers lamination**

(1) Low-Iron Tempered Glass+ (2) EVA + (3) PV Cells + (4) EVA + (5) Backsheet

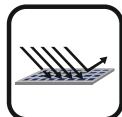

**High Transmission Tempered Glass:**

Minimal sun light reflection guaranteed



**Anodized Aluminum Frame:**

Corrosion-resistance and structural strength



**Connection:**

Junction box IP65

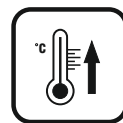

**High temperature resistant:**

Operation Range: -40 to +85°C



**Guaranteed Output Power 80%:**

During first 25 years



**Guaranteed Output Power 90%:**

During first 10 years



**Product Warranty**

5 years on materials and assembly

# Technical Features / Características Técnicas XMA SOLAR PANEL

## XPV-080-18VP

### Electric Specifications (STC\*)

Peak power / Potencia máxima (Pmax)	80W
Cell efficiency / Eficiencia	18.81%
Max. power voltage / Voltaje a potencia max. (Vmp)	19.1V
Max. power current / Corriente a potencia max.	4.19A
Open circuit voltage / Voltaje en abierto (Voc)	22.7V
Short circuit current / Corriente de corto circuito (Isc)	4.41A
Power tolerance / Tolerancia de potencia	3%
Max. system voltage / Voltaje max. del sistema	800V
Series fuse rating / Valor fusibles en serie	6A
Qty. bypass diodes / Cantidad de diodos de bypass	2 x 10A

(\* Irradiance: 1000W/m<sup>2</sup> / AM1.5G, Module T: 25°C

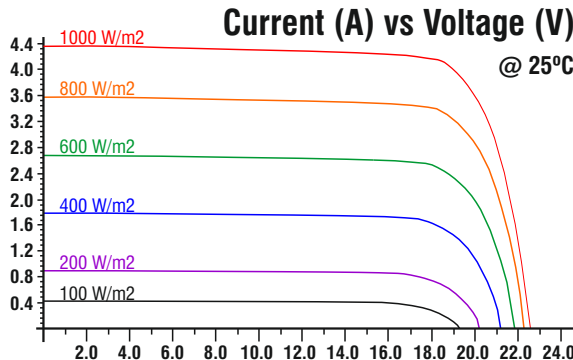

### Temperature Characteristics

Nominal Operating Temperature / Temp. de operación	46 +/- 2°C
Operating range / Rango de operación	-40 to 85°C
Isc coefficient / Coeficiente (a I <sub>sc</sub> )	0.08%/°C
Voc coefficient / Coeficiente Temp (b Voc)	-0.32%/°C
Pmax coefficient / Coeficiente (g P <sub>max</sub> )	-0.38%/°C

### Output Power vs Years of Operation

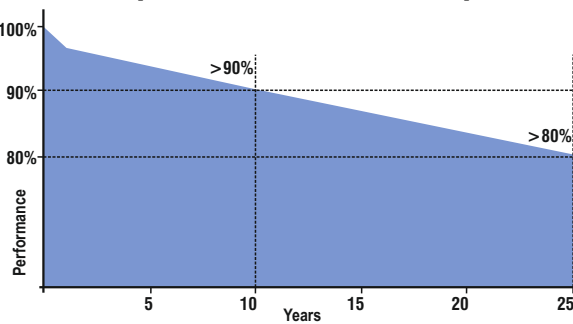

### Connections

Junction Box / Caja de conexiones	PV-BX2020C
Connectors / Conectores	(+) & (-) MC4 (type IV)
Cables	Dia: 2.5mm <sup>2</sup> - L: 0.9m

### Physical Specifications

Dimensions / Tamaño	770*670*25mm
Weight / Peso	5.4Kg
Solar Cells Arrangement / Cantidad de celdas	36 in series (4*9)
Panel Construcción / Estructura del Panel	5 layers
Tempered Glass / Cristal Templado (EN 1096-4:2004)	High transmission, low-iron Solar Glass / Cristal Solar Anti reflectivo de bajo-hierro (3.2mm)
Backsheet / Laminado trasero (Toyol - TUV)	QPL High Reflectance Anti-UV long lifetime / QPL reflectante / Anti-UV / de larga vida (0.25mm)
EVA: Ethylene Vinyl Acetate (First - UL)	High light transmission + High UV Block / De alta transmisión de luz + alto bloqueo UV (0.45mm)
Solar Cells / Celdas solares (Taiwan # 1 Manufacturer)	"A" grade manufactured in Taiwan / Grado "A" fabricada en Taiwan
Junction Box / Caja de Conexión	IP65
Frame / Marco	High corrosion resistance anodized aluminium / Aluminio anodizado resistente a corrosión

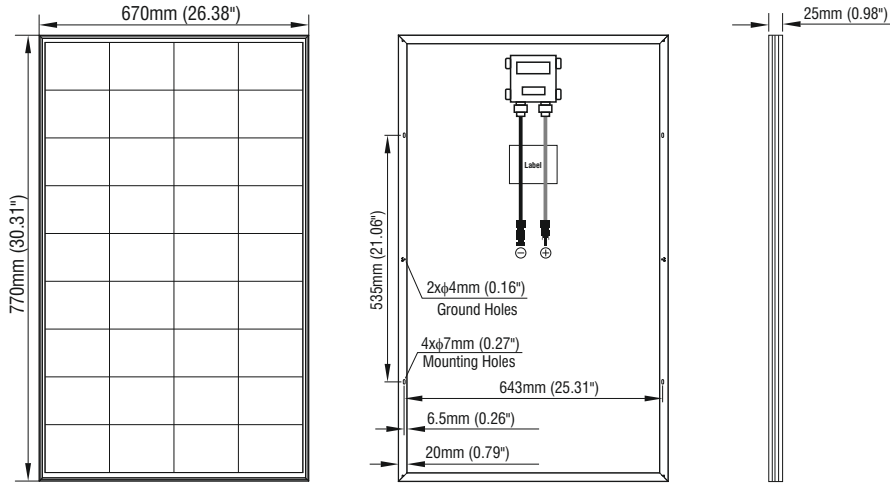

## XMA SOLAR PANEL

# XPV-100-18VP

## Polycrystalline PV Solar Panel

### Polycrystal Solar Panel

**100W / 36 cells in series / 18V**

High efficiency solar cells

High performance with low light conditions.

For severe environmental conditions.

Manufactured with high quality components.



High Efficiency Polycrystal



Voltage at Maximum Power



Cells in Series



### Outstandings Features



#### 5 Layers lamination

(1) Low-Iron Tempered Glass+ (2) EVA + (3) PV Cells + (4) EVA + (5) Backsheet

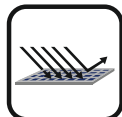

#### High Transmission Tempered Glass:

Minimal sun light reflection guaranteed



#### Anodized Aluminum Frame:

Corrosion-resistance and structural strength



#### Connection:

Junction box IP65

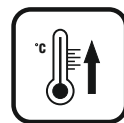

#### High temperature resistant:

Operation Range: -40 to +85°C



#### Guaranteed Output Power 80%:

During first 25 years



#### Guaranteed Output Power 90%:

During first 10 years



#### Product Warranty

5 years on materials and assembly

# Technical Features / Características Técnicas XMA SOLAR PANEL

## XPV-100-18VP

### Electric Specifications (STC\*)

Peak power / Potencia máxima (Pmax)	100W
Cell efficiency / Eficiencia	17.64%
Max. power voltage / Voltaje a potencia max. (Vmp)	18.7V
Max. power current / Corriente a potencia max.	5.35A
Open circuit voltage / Voltaje en abierto (Voc)	22.3V
Short circuit current / Corriente de corto circuito (Isc)	5.69A
Power tolerance / Tolerancia de potencia	3%
Max. system voltage / Voltaje max. del sistema	800V
Series fuse rating / Valor fusibles en serie	8A
Qty. bypass diodes / Cantidad de diodos de bypass	2 x 10A

(\* Irradiance: 1000W/m<sup>2</sup> / AM1.5G, Module T: 25°C

### Current (A) vs Voltage (V)

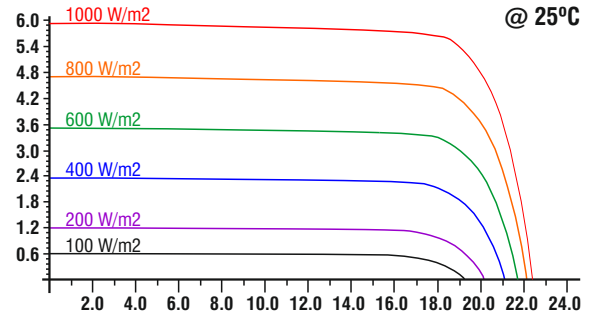

### Temperature Characteristics

Nominal Operating Temperature / Temp. de operación	46 +/- 2°C
Operating range / Rango de operación	-40 to 85°C
Isc coefficient / Coeficiente (a <sub>Isc</sub> )	0.08%/°C
Voc coefficient / Coeficiente Temp (b <sub>Voc</sub> )	-0.32%/°C
Pmax coefficient / Coeficiente (g <sub>Pmax</sub> )	-0.38%/°C

### Output Power vs Years of Operation

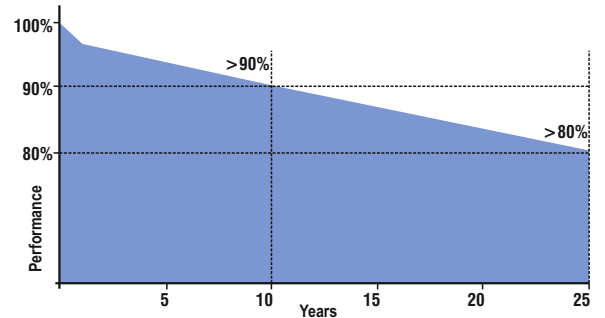

### Connections

Junction Box / Caja de conexiones	PV-BX2020C
Connectors / Conectores	(+) & (-) MC4 (type IV)
Cables	Dia: 2.5mm <sup>2</sup> - L: 0.9m

### Physical Specifications

Dimensions / Tamaño	1015*670*30mm
Weight / Peso	7.2Kg
Solar Cells Arrangement / Cantidad de celdas	36 in series (4*9)
Panel Construcción / Estructura del Panel	5 layers
Tempered Glass / Cristal Templado (EN 1096-4:2004)	High transmission, low-iron Solar Glass / Cristal Solar Anti reflectivo de bajo-hierro (3.2mm)
Backsheet / Laminado trasero (Toyol - TUV)	QPL High Reflectance Anti-UV long lifetime / QPL reflectante / Anti-UV / de larga vida (0.25mm)
EVA: Ethylene Vinyl Acetate (First - UL)	High light transmission + High UV Block / De alta transmisión de luz + alto bloqueo UV (0.45mm)
Solar Cells / Celdas solares (Taiwan # 1 Manufacturer)	"A" grade manufactured in Taiwan / Grado "A" fabricada en Taiwan
Junction Box / Caja de Conexión	IP65
Frame / Marco	High corrosion resistance anodized aluminium / Aluminio anodizado resistente a corrosión

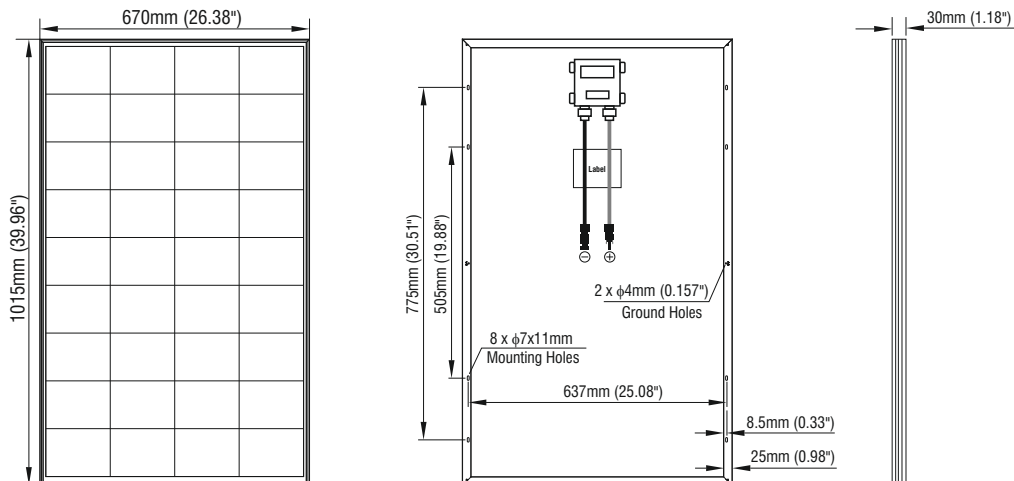

## XMA SOLAR PANEL

# XPV-120-18VP

## Polycrystalline PV Solar Panel

### Polycrystal Solar Panel

**120W / 36 cells in series / 18V**

High efficiency solar cells

High performance with low light conditions.

For severe environmental conditions.

Manufactured with high quality components.



High Efficiency Polycrystal



Voltage at Maximum Power



Cells in Series



## Outstandings Features



### 5 Layers lamination

(1) Low-Iron Tempered Glass + (2) EVA +  
(3) PV Cells + (4) EVA + (5) Backsheet

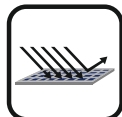

### High Transmission Tempered Glass:

Minimal sun light reflection guaranteed



### Anodized Aluminum Frame:

Corrosion-resistance and structural strength



### Connection:

Junction box IP65

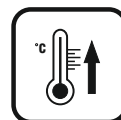

### High temperature resistant:

Operation Range: -40 to +85°C



### Guaranteed Output Power 80%:

During first 25 years



### Guaranteed Output Power 90%:

During first 10 years



### Product Warranty

5 years on materials and assembly

# Technical Features / Características Técnicas XMA SOLAR PANEL

## XPV-120-18VP

### Electric Specifications (STC\*)

Peak power / Potencia máxima (Pmax)	120W
Cell efficiency / Eficiencia	18.81%
Max. power voltage / Voltaje a potencia max. (Vmp)	19.1V
Max. power current / Corriente a potencia max.	6.28A
Open circuit voltage / Voltaje en abierto (Voc)	22.8V
Short circuit current / Corriente de corto circuito (Isc)	6.61A
Power tolerance / Tolerancia de potencia	3%
Max. system voltage / Voltaje max. del sistema	1.000V
Series fuse rating / Valor fusibles en serie	10A
Qty. bypass diodes / Cantidad de diodos de bypass	2 x 10A

Current (A) vs Voltage (V)

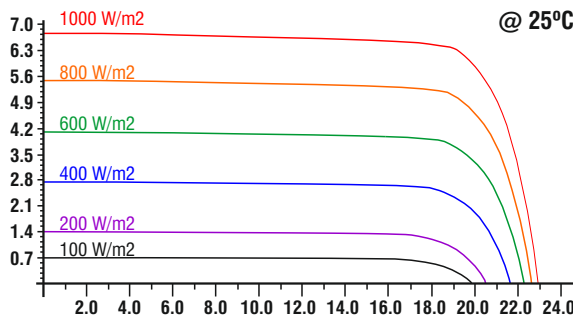

### Temperature Characteristics

Nominal Operating Temperature / Temp. de operación	46 +/- 2°C
Operating range / Rango de operación	-40 to 85°C
Isc coefficient / Coeficiente (a <sub>Isc</sub> )	0.08%/°C
Voc coefficient / Coeficiente Temp (b <sub>Voc</sub> )	-0.32%/°C
Pmax coefficient / Coeficiente (g <sub>Pmax</sub> )	-0.38%/°C

Output Power vs Years of Operation

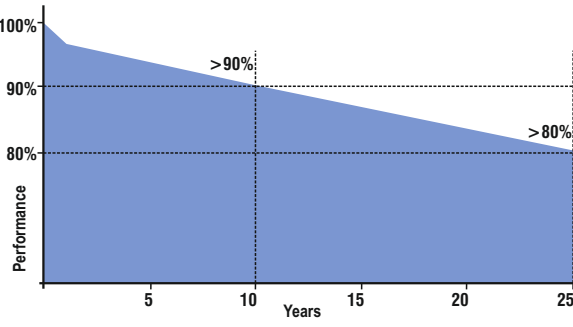

### Connections

Junction Box / Caja de conexiones	PV-BX2020C
Connectors / Conectores	(+) & (-) MC4 (type IV)
Cables	Dia: 2.5mm <sup>2</sup> - L: 0.9m

### Physical Specifications

Dimensions / Tamaño	1120*670*30mm
Weight / Peso	8.0Kg
Solar Cells Arrangement / Cantidad de celdas	36 in series (4*9)
Panel Construcción / Estructura del Panel	5 layers
Tempered Glass / Cristal Templado (EN 1096-4:2004)	High transmission, low-iron Solar Glass / Cristal Solar Anti reflectivo de bajo-hierro (3.2mm)
Backsheet / Laminado trasero (Toyol - TUV)	QPL High Reflectance Anti-UV long lifetime / QPL reflectante / Anti-UV / de larga vida (0.25mm)
EVA: Ethylene Vinyl Acetate (First - UL)	High light transmission + High UV Block / De alta transmisión de luz + alto bloqueo UV (0.45mm)
Solar Cells / Celdas solares (Taiwan # 1 Manufacturer)	"A" grade manufactured in Taiwan / Grado "A" fabricada en Taiwan
Junction Box / Caja de Conexión	IP65
Frame / Marco	High corrosion resistance anodized aluminium / Aluminio anodizado resistente a corrosión

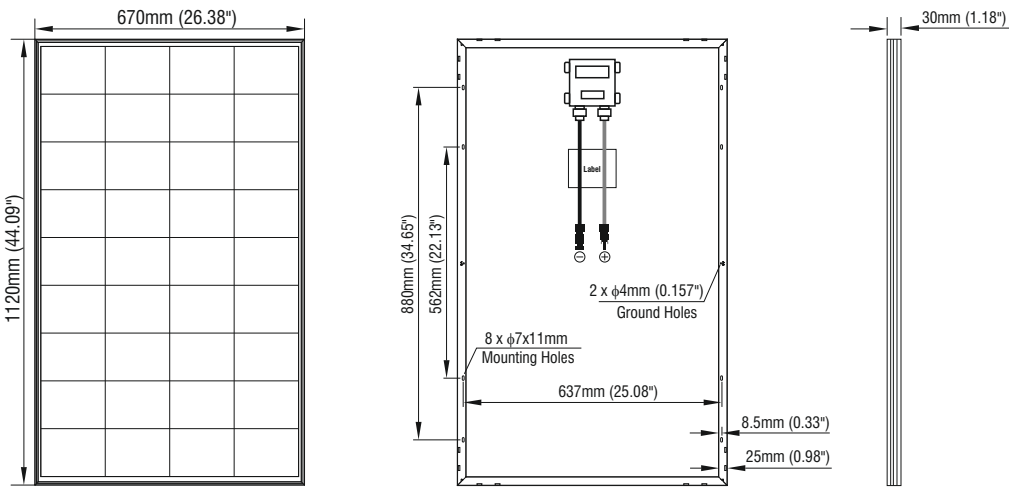

## XMA SOLAR PANEL

# XPV-160-18M

## Monocrystalline PV Solar Panel

### Monocrystal Solar Panel (Perc)

**160W / 33 cells / 18V**

High efficiency solar cells

High performance with low light conditions.

For severe environmental conditions.

Manufactured with high quality components.

**MONO**  
**160W**

High Efficiency Monocrystal

**VMP**  
**18**

Voltage at Maximum Power

**33**  

Cells in Series



## Outstandings Features

**5**  

### 5 Layers lamination

(1) Low-Iron Tempered Glass + (2) EVA +  
(3) PV Cells + (4) EVA + (5) Backsheet



### High Transmission Tempered Glass:

Minimal sun light reflection guaranteed

**AI**

### Anodized Aluminum Frame:

Corrosion-resistance and structural strength



### Connection:

Junction box IP65



### High temperature resistant:

Operation Range: -40 to +85°C

**80%**  
**25**  
**YEARS**

### Guaranteed Output Power 80%:

During first 25 years

**90%**  
**10**  
**YEARS**

### Guaranteed Output Power 90%:

During first 10 years

**Product**  
**5**  
**YEARS**

### Product Warranty

5 years on materials and assembly

**Technical Features / Características Técnicas** **XPV SOLAR PANEL**

# XPV-160-18M

## Electric Specifications (STC\*)

Peak power / Potencia máxima (Pmax)	160W
Cell efficiency / Eficiencia	19.34%
Max. power voltage / Voltaje a potencia max. (Vmp)	18.5V
Max. power current / Corriente a potencia max.	8.66A
Open circuit voltage / Voltaje en abierto (Voc)	21.5V
Short circuit current / Corriente de corto circuito (Isc)	9.31A
Power tolerance / Tolerancia de potencia	3%
Max. system voltage / Voltaje max. del sistema	1.000V
Series fuse rating / Valor fusibles en serie	15A

(\* Irradiance: 1000W/m<sup>2</sup> / AM1.5G, Module T: 25°C

## Temperature Characteristics

Nominal Operating Temperature / Temp. de operación	45 +/- 2°C
Operating range / Rango de operación	-40 to 85°C
Isc coefficient / Coeficiente (a_Isc)	0.08%/°C
Voc coefficient / Coeficiente Temp (b_Voc)	-0.32%/°C
Pmax coefficient / Coeficiente (g_Pmax).	-0.38%/°C

## Connections

Junction Box / Caja de conexiones	IP-65
Connectors / Conectores	(+) & (-) MC4 (type IV)
Cables	Dia: 2.5mm <sup>2</sup> - L: 0.7m

## Physical Specifications

Dimensions / Tamaño	1230*670*30mm
Weight / Peso	7.5Kg
Solar Cells Arrangement / Cantidad de celdas	33: 3*11 (Size: 210*105mm)
Panel Construcción / Estructura del Panel	5 layers
Tempered Glass / Cristal Templado (EN 1096-4:2004)	High transmission, low-iron Solar Glass / Cristal Solar Anti reflectivo de bajo-hierro (3.2mm)
Frame / Marco	High corrosion resistance anodized aluminium / Aluminio anodizado resistente a corrosión
EVA: Ethylene Vinyl Acetate (First - UL)	High light transmission + High UV Block / De alta transmisión de luz + alto bloqueo UV (0.45mm)
Solar Cells / Celdas solares (Taiwan # 1 Manufacturer)	"A" grade manufactured in Taiwan / Grado "A" fabricada en Taiwan
Max. Load (snow) / Carga Nieve Max.	2400 Pa
Max. Impact Resistance / Resistencia a impactos	Metal ball 227g at 1m height / Una bola de acero de 227g cayendo desde 1 metro de altura

Current (A) vs Voltage (V)

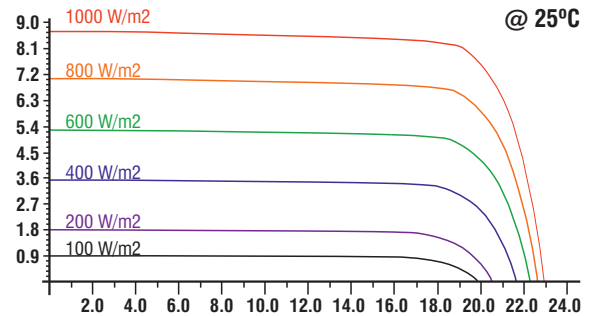

Output Power vs Years of Operation

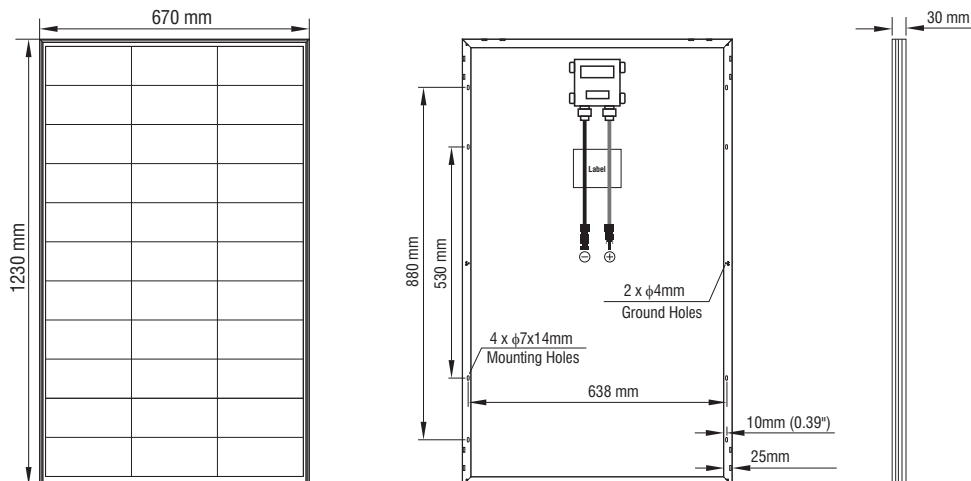
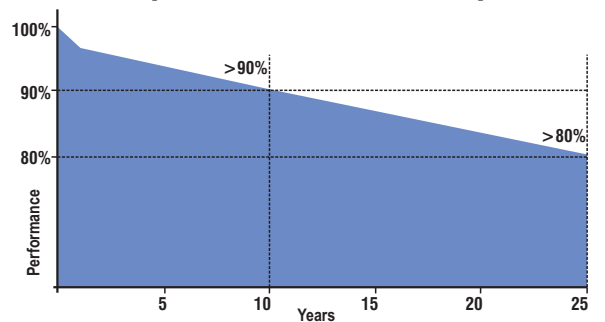

## XMA SOLAR PANEL

# XPV-200-36VP

## Polycrystalline PV Solar Panel

### Polycrystal Solar Panel

**200W / 72 cells in series / 36V**

High efficiency solar cells

High performance with low light conditions.

For severe environmental conditions.

Manufactured with high quality components.



**POLY**  
**200W**

High Efficiency Polycrystal

**VMP**  
**36**

Voltage at Maximum Power

**72**  

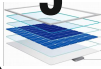

Cells in Series

## Outstandings Features

**5**  

**5 Layers lamination**

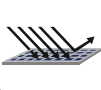
(1) Low-Iron Tempered Glass + (2) EVA +  
(3) PV Cells + (4) EVA + (5) Backsheet



**High Transmission Tempered Glass:**

Minimal sun light reflection guaranteed

**AI**  



**Anodized Aluminum Frame:**

Corrosion-resistance and structural strength



**Connection:**

Junction box IP65



**High temperature resistant:**

Operation Range: -40 to +85°C

**80%**  
**25**  
**YEARS**

**Guaranteed Output Power 80%:**

During first 25 years

**90%**  
**10**  
**YEARS**

**Guaranteed Output Power 90%:**

During first 10 years

**Product**  
**5**  
**YEARS**

**Product Warranty**

5 years on materials and assembly

# Technical Features / Características Técnicas XMA SOLAR PANEL

## XPV-200-36VP

### Electric Specifications (STC\*)

Peak power / Potencia máxima (Pmax)	200W
Cell efficiency / Eficiencia	17.64%
Max. power voltage / Voltaje a potencia max. (Vmp)	37.5V
Max. power current / Corriente a potencia max.	5.33A
Open circuit voltage / Voltaje en abierto (Voc)	44.6V
Short circuit current / Corriente de corto circuito (Isc)	5.70A
Power tolerance / Tolerancia de potencia	3%
Max. system voltage / Voltaje max. del sistema	1.000V
Series fuse rating / Valor fusibles en serie	10A
Qty. bypass diodes / Cantidad de diodos de bypass	3 x 30A (30SQ045)

(\* Irradiance: 1000W/m<sup>2</sup> / AM1.5G, Module T: 25°C

### Temperature Characteristics

Nominal Operating Temperature / Temp. de operación	46 +/- 2°C
Operating range / Rango de operación	-40 to 85°C
Isc coefficient / Coeficiente (a <sub>Isc</sub> )	0.08%/°C
Voc coefficient / Coeficiente Temp (b <sub>Voc</sub> )	-0.32%/°C
Pmax coefficient / Coeficiente (g <sub>Pmax</sub> )	-0.38%/°C

### Connections

Junction Box / Caja de conexiones	GZX-156K
Connectors / Conectores	(+) & (-) MC4 (type IV)
Cables	Dia: 4mm <sup>2</sup> - L: 0.9m

### Physical Specifications

Dimensions / Tamaño	1320*990*35mm
Weight / Peso	14.0Kg
Solar Cells Arrangement / Cantidad de celdas	72 in series (6*12)
Panel Construcción / Estructura del Panel	5 layers
Tempered Glass / Cristal Templado (EN 1096-4:2004)	High transmission, low-iron Solar Glass / Cristal Solar Anti reflectivo de bajo-hierro (3.2mm)
Backsheet / Laminado trasero (Toyol - TUV)	QPL High Reflectance Anti-UV long lifetime / QPL reflectante / Anti-UV / de larga vida (0.25mm)
EVA: Ethylene Vinyl Acetate (First - UL)	High light transmission + High UV Block / De alta transmisión de luz + alto bloqueo UV (0.45mm)
Solar Cells / Celdas solares (Taiwan # 1 Manufacturer)	"A" grade manufactured in Taiwan / Grado "A" fabricada en Taiwan
Junction Box / Caja de Conexión	IP67 (GZX)
Frame / Marco	High corrosion resistance anodized aluminium / Aluminio anodizado resistente a corrosión

### Current (A) vs Voltage (V)

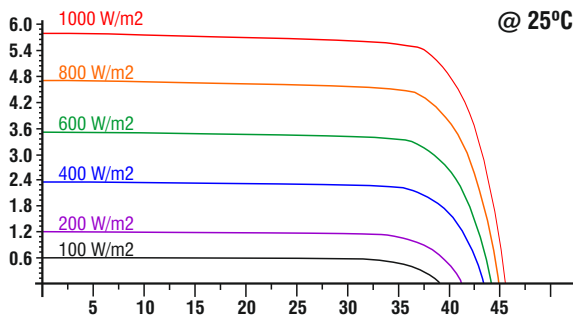

### Output Power vs Years of Operation

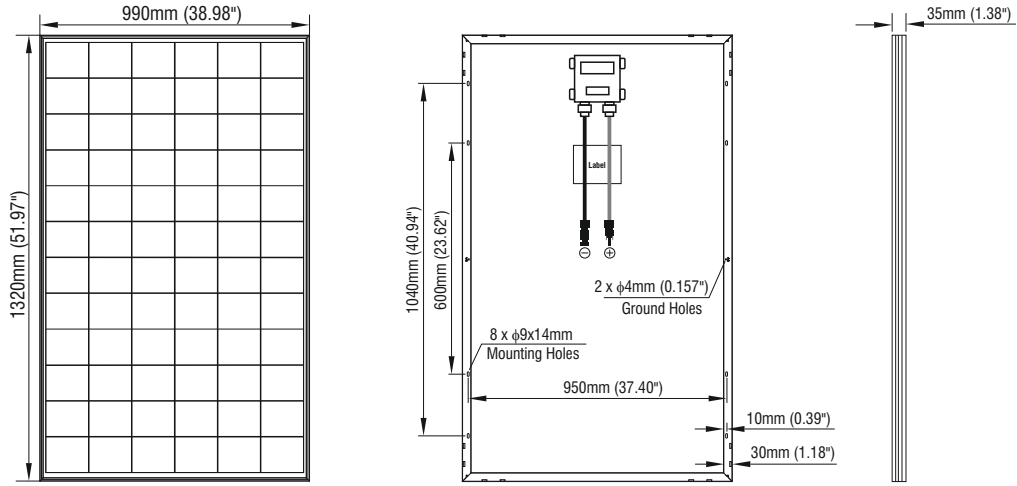
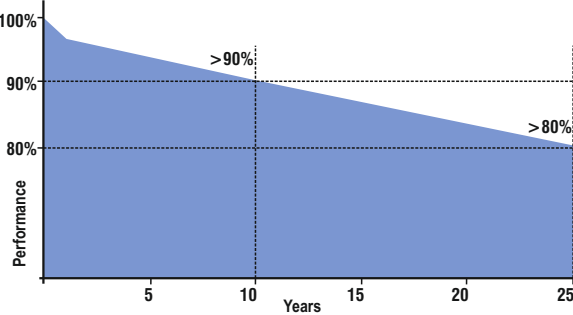

## XMA SOLAR PANEL

# XPV-270-30VP

## Polycrystalline PV Solar Panel

### Polycrystal Solar Panel 270W / 60 celdas en serie / 30V

High efficiency solar cells.  
High performance with low light conditions.  
For severe environmental conditions.  
Manufactured with high quality components.

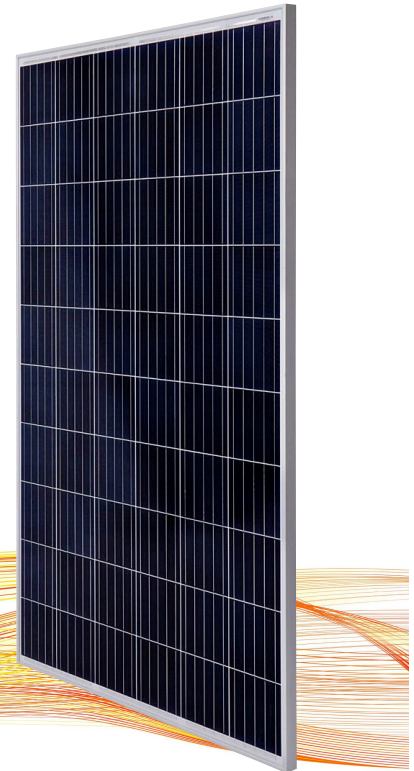

- POLY 270W** High Efficiency Polycrystal
- VMP 30** Voltage at Maximum Power
- 60** Cells in Series

## Outstandings Features

- 5** 5 Layers lamination  
(1) Low-Iron Tempered Glass + (2) EVA + (3) PV Cells + (4) EVA + (5) Backsheet
- High Transmission Tempered Glass:**  
Minimal sun light reflection guaranteed
- AI** Anodized Aluminum Frame:  
Corrosion-resistance and structural strength
- Conection:**  
4mm2 Cables with MC4 (+) (-) Connectors

- High temperature resistant:**  
Operation Range: -40 to +85°C
- 80% 25 YEARS** Guaranteed Output Power 80%:  
During first 25 years
- 90% 10 YEARS** Guaranteed Output Power 90%:  
During first 10 years
- Product 5 YEARS** Product Warranty  
5 years on materials and assembly

# Technical Features / Características Técnicas XMA SOLAR PANEL

## XPV-270-30VP

### Electric Specifications (STC\*)

Peak power / Potencia máxima (Pmax)	270W
Cell efficiency / Eficiencia	19.23%
Max. power voltage / Voltaje a potencia max. (Vmp)	32.2V
Max. power current / Corriente a potencia max.	8.39A
Open circuit voltage / Voltaje en abierto (Voc)	38.2V
Short circuit current / Corriente de corto circuito (Isc)	8.87A
Power tolerance / Tolerancia de potencia	3%
Max. system voltage / Voltaje max. del sistema	1.000V
Series fuse rating / Valor fusibles en serie	12A
Qty. bypass diodes / Cantidad de diodos de bypass	3 x 30A (30SQ045)

(\* Irradiance: 1000W/m<sup>2</sup> / AM1.5G, Module T: 25°C

### Temperature Characteristics

Nominal Operating Temperature / Temp. de operación	46 +/- 2°C
Operating range / Rango de operación	-40 to 85°C
Isc coefficient / Coeficiente (a <sub>Isc</sub> )	0.08%/°C
Voc coefficient / Coeficiente Temp (b <sub>Voc</sub> )	-0.32%/°C
Pmax coefficient / Coeficiente (g <sub>Pmax</sub> )	-0.38%/°C

### Connections

Junction Box / Caja de conexiones	GZX-156K
Connectors / Conectores	(+) & (-) MC4 (type IV)
Cables	Dia: 4mm <sup>2</sup> - L: 0.9m

### Physical Specifications

Dimensions / Tamaño	1640*990*40mm
Weight / Peso	18.0Kg
Solar Cells Arrangement / Cantidad de celdas	60 in series (6*10)
Panel Construcción / Estructura del Panel	5 layers
Tempered Glass / Cristal Templado (EN 1096-4:2004)	High transmission, low-iron Solar Glass / Cristal Solar Anti reflectivo de bajo-hierro (3.2mm)
Backsheet / Laminado trasero (Toyol - TUV)	FPL High Reflectance Anti-UV long lifetime / FPL reflectante / Anti-UV / de larga vida (0.334mm)
EVA: Ethylene Vinyl Acetate (First - UL)	High light transmission + High UV Block / De alta transmisión de luz + alto bloqueo UV (0.45mm)
Solar Cells / Celdas solares (Taiwan # 1 Manufacturer)	"A" grade manufactured in Taiwan / Grado "A" fabricada en Taiwan
Junction Box / Caja de Conexión	IP67 (GZX)
Frame / Marco	High corrosion resistance anodized aluminium / Aluminio anodizado resistente a corrosión

### Current (A) vs Voltage (V)

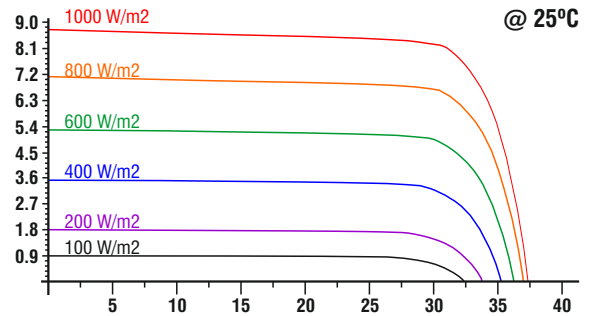

### Output Power vs Years of Operation

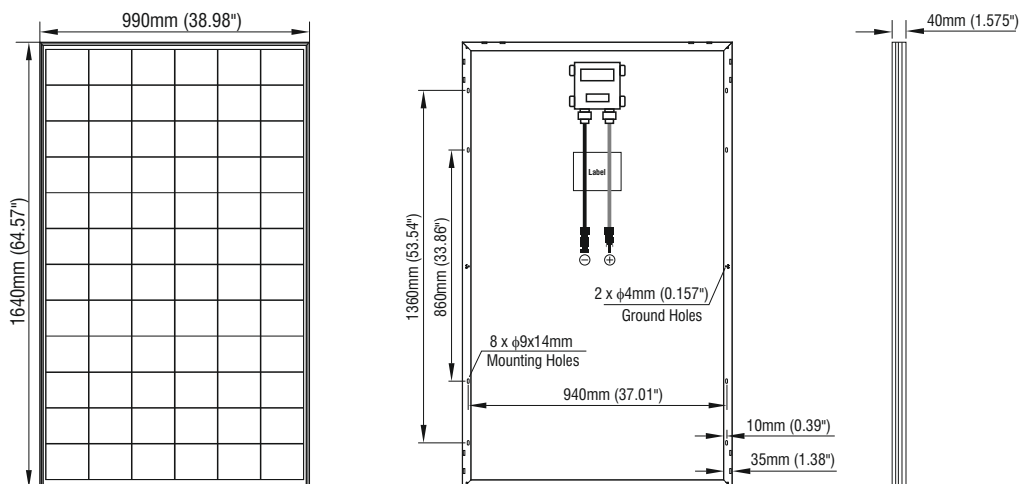
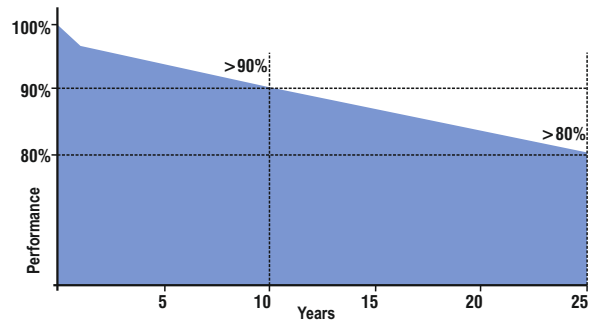

## XMA SOLAR PANEL

### XPV-320-36VP

### Polycrystalline PV Solar Panel

#### Polycrystal Solar Panel

**320W / 72 cells in series / 36V**

High efficiency solar cells.

High performance with low light conditions.

For severe environmental conditions.

Manufactured with high quality components.



**POLY**  
**320W**

Polycrystal - Max. Power 320W:  
High efficiency polycrystal cells

**VMP**  
**36**

Voltage at Maximum Power

**72**  

Cells in Series

#### Outstandings Features

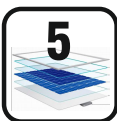

**5**

##### 5 Layers lamination

(1) Low-Iron Tempered Glass + (2) EVA +  
(3) PV Cells + (4) EVA + (5) Backsheet

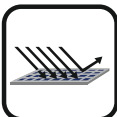

##### High Transmission Tempered Glass:

Minimal sun light reflection guaranteed



**AI**

##### Anodized Aluminum Frame:

Corrosion-resistance and structural strength

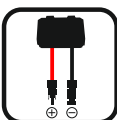

##### Conection:

4mm2 Cables with MC4 (+) (-) connectors

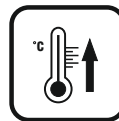

##### High temperature resistant:

Operation Range: -40 to +85°C



**80%**  
**25**  
**YEARS**

##### Guaranteed Output Power 80%:

During first 25 years



**90%**  
**10**  
**YEARS**

##### Guaranteed Output Power 90%:

During first 10 years



**Product**  
**5**  
**YEARS**

##### Product Warranty

5 years on materials and assembly

**Technical Features / Características Técnicas** **XMA SOLAR PANEL**

# XPV-320-36VP

## Electric Specifications (STC\*)

Peak power / Potencia máxima (Pmax)	320W
Cell efficiency / Eficiencia	19.17%
Max. power voltage / Voltaje a potencia max. (Vmp)	38.4V
Max. power current / Corriente a potencia max.	8.34A
Open circuit voltage / Voltaje en abierto (Voc)	45.6V
Short circuit current / Corriente de corto circuito (Isc)	8.82A
Power tolerance / Tolerancia de potencia	3%
Max. system voltage / Voltaje max. del sistema	1.000V
Series fuse rating / Valor fusibles en serie	12A
Qty. bypass diodes / Cantidad de diodos de bypass	3 x 30A (30SQ045)

(\* Irradiance: 1000W/m<sup>2</sup> / AM1.5G, Module T: 25°C

**Current (A) vs Voltage (V)**

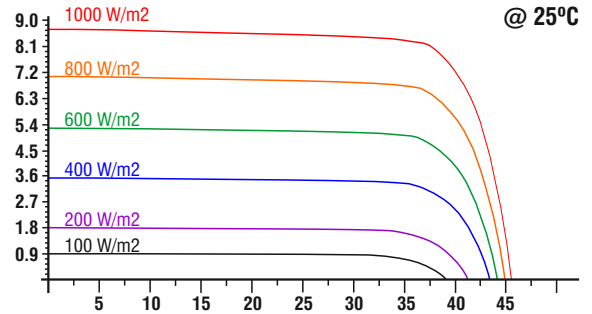

## Temperature Characteristics

Nominal Operating Temperature / Temp. de operación	46 +/- 2°C
Operating range / Rango de operación	-40 to 85°C
Isc coefficient / Coeficiente (a_Isc)	0.08%/°C
Voc coefficient / Coeficiente Temp (b_Voc)	-0.32%/°C
Pmax coefficient / Coeficiente (g_Pmax)	-0.38%/°C

**Output Power vs Years of Operation**

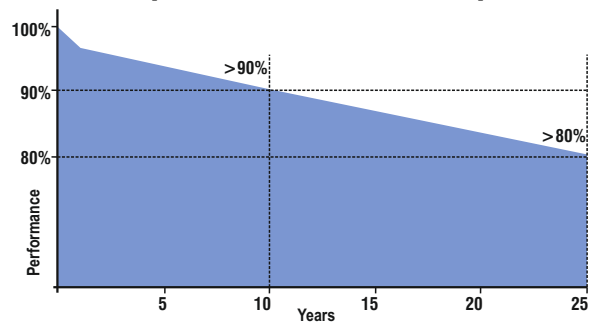

## Connections

Junction Box / Caja de conexiones	GZX-156K
Connectors / Conectores	(+) & (-) MC4 (type IV)
Cables	Dia: 4mm <sup>2</sup> - L: 0.9m

## Physical Specifications

Dimensions / Tamaño	1956*992*45mm
Weight / Peso	21.5Kg
Solar Cells Arrangement / Cantidad de celdas	72 in series (6*12)
Panel Construcción / Estructura del Panel	5 layers
Tempered Glass / Cristal Templado (EN 1096-4:2004)	High transmission, low-iron Solar Glass / Cristal Solar Anti reflectivo de bajo-hierro (3.2mm)
Backsheet / Laminado trasero (Toyol - TUV)	FPL High Reflectance Anti-UV long lifetime / FPL reflectante / Anti-UV / de larga vida (0.334mm)
EVA: Ethylene Vinyl Acetate (First - UL)	High light transmission + High UV Block / De alta transmisión de luz + alto bloqueo UV (0.45mm)
Solar Cells / Celdas solares (Taiwan # 1 Manufacturer)	"A" grade manufactured in Taiwan / Grado "A" fabricada en Taiwan
Junction Box / Caja de Conexión	IP67 (GZX)
Frame / Marco	High corrosion resistance anodized aluminium / Aluminio anodizado resistente a corrosión

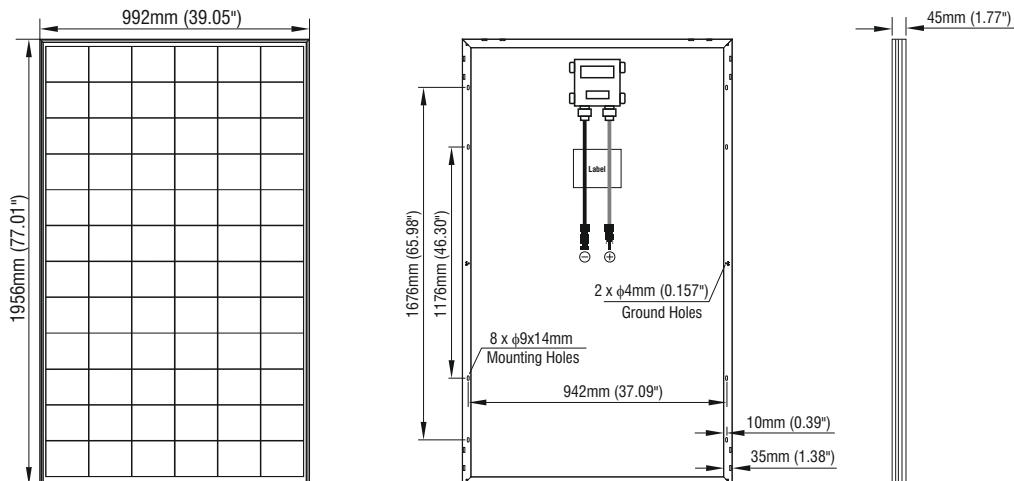

## XMA SOLAR PANEL

# XPV-330-34M

## Monocrystalline PV Solar Panel

### Monocrystal Solar Panel (PERC Tech.)

**330W / 60 cells in series / 34V**

High efficiency monocrystalline solar cells.

With PERC technology

High performance with low light conditions.

For severe environmental conditions.

Manufactured with high quality components.



**MONO  
330W**

**Monocrystal - Max. Power 330W:**  
High efficiency Monocrystal cells

**VMP  
34**

**Voltage at Maximum Power**

**60**

**Cells in Series**

## Outstandings Features

**5**

**5 Layers lamination**

(1) Low-Iron Tempered Glass + (2) EVA +  
(3) PV Cells + (4) EVA + (5) Backsheet

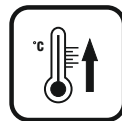

**High temperature resistant:**

Operation Range: -40 to +85°C

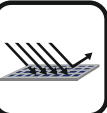

**High Transmission Tempered Glass:**

Minimal sun light reflection guaranteed



**Guaranteed Output Power 80%:**

During first 25 years

**AI**

**Anodized Aluminum Frame:**

Corrosion-resistance and structural strength



**Guaranteed Output Power 90%:**

During first 10 years

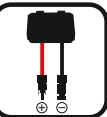

**Conection:**

4mm2 Cables with MC4 (+) (-) connectors



**Product Warranty**

5 years on materials and assembly

**Technical Features / Características Técnicas** **XMA SOLAR PANEL**

# XPV-330-34M

## Electric Specifications (STC\*)

Peak power / Potencia máxima (Pmax)	330W
Cell efficiency / Eficiencia	22.26%
Max. power voltage / Voltaje a potencia max. (Vmp)	34.0V
Max. power current / Corriente a potencia max.	9.71A
Open circuit voltage / Voltaje en abierto (Voc)	40.3V
Short circuit current / Corriente de corto circuito (Isc)	10.34A
Power tolerance / Tolerancia de potencia	3%
Max. system voltage / Voltaje max. del sistema	1.000V
Series fuse rating / Valor fusibles en serie	15A
Qty. bypass diodes / Cantidad de diodos de bypass	3

(\* Irradiance: 1000W/m<sup>2</sup> / AM1.5G, Module T: 25°C

## Temperature Characteristics

Nominal Operating Temperature / Temp. de operación (NOTC)	46 +/- 2°C
Operating range / Rango de operación	-40 to 85°C
Isc coefficient / Coeficiente (a <sub>Isc</sub> )	0.03%/°C
Voc coefficient / Coeficiente Temp (b <sub>Voc</sub> )	-0.32%/°C
Pmax coefficient / Coeficiente (g <sub>Pmax</sub> )	-0.42%/°C

## Connections

Junction Box / Caja de conexiones	GZX-156K
Connectors / Conectores	(+) & (-) MC4 (type IV)
Cables	Dia: 4mm <sup>2</sup> - L: 900mm

## Physical Specifications

Dimensions / Tamaño	1650*992*35mm
Weight / Peso	17.5Kg
Solar Cells Arrangement / Cantidad de celdas	60 in series (6*10)
Panel Construcción / Estructura del Panel	5 layers
Tempered Glass / Cristal Templado (EN 1096-4:2004)	High transmission, low-iron Solar Glass / Cristal Solar Anti reflectivo de bajo-hierro (3.2mm)
Backsheet / Laminado trasero (Toyol - TUV)	FPL High Reflectance Anti-UV long lifetime / FPL reflectante / Anti-UV / de larga vida (0.334mm)
EVA: Ethylene Vinyl Acetate (First - UL)	High light transmission + High UV Block / De alta transmisión de luz + alto bloqueo UV (0.45mm)
Solar Cells / Celdas solares (Taiwan # 1 Manufacturer)	"A" grade manufactured in Taiwan / Grado "A" fabricada en Taiwan
Junction Box / Caja de Conexión	IP67 (GZX)
Frame / Marco	High corrosion resistance anodized aluminium / Aluminio anodizado resistente a corrosión

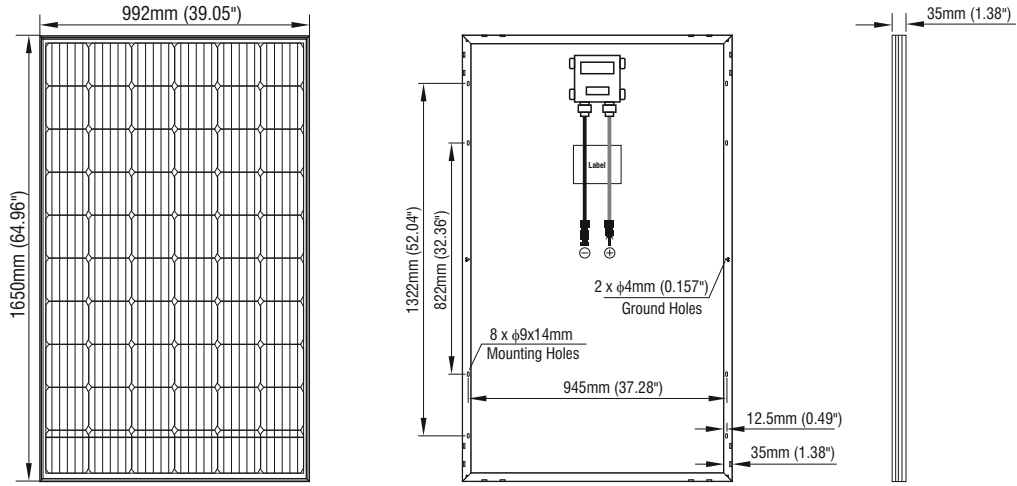
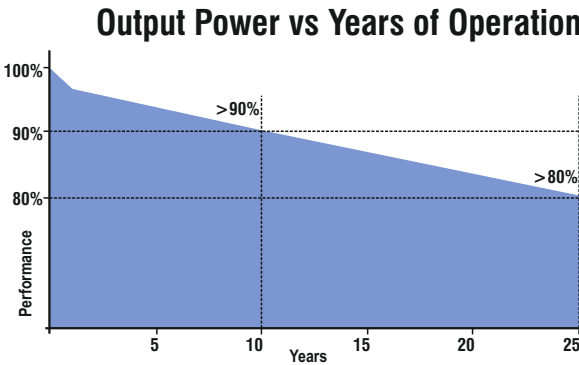
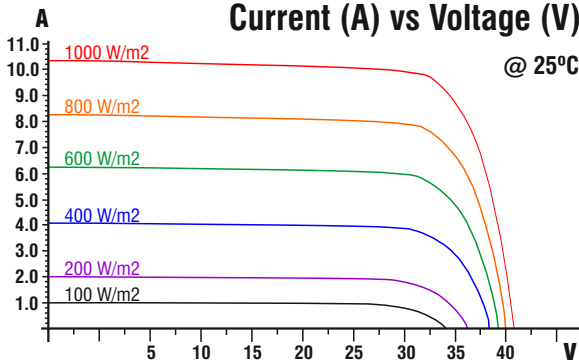

## XMA SOLAR PANEL

# XPV-545-42M

## Monocrystalline PV Solar Panel

### Monocrystal Solar Panel (PERC Tech.)

**545W / 144 cells in series / 42V**

High efficiency monocrystalline solar cells.

With PERC technology

High performance with low light conditions.

For severe environmental conditions.

Manufactured with high quality components.



**MONO**  
**545W**

Monocrystal + PERC - Max. Power 545W (STC\*):  
High efficiency Monocrystal cells

**VMP**  
**42**

Voltage at Maximum Power

**144**  



144 Cells in Series: 2x(6x12) 182\*91mm type

## Outstandings Features

**5**

**5 Layers lamination:**

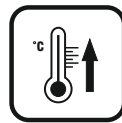
(1) Low-Iron Tempered Glass + (2) EVA +  
(3) PV Cells + (4) EVA + (5) Backsheet



**High temperature resistant:**

Operation Range: -40 to +85°C

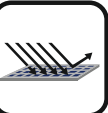

**3.2mm Low Iron, High Transmission Tempered Glass:**

Minimal sun light reflection guaranteed



**Guaranteed Output Power 84%:**

During first 25 years

**AI**

**Anodized Aluminum Frame:**

Corrosion-resistance and structural strength



**Guaranteed Output Power 90%:**

During first 10 years

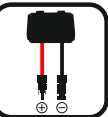

**Connection:**

4mm2 Cables with MC4 (+) (-) connectors



**Product Warranty**

5 years on materials and assembly

# Technical Features / Características Técnicas XMA SOLAR PANEL

## XPV-545-42M

### Electric Specifications (STC\*)

Peak power / Potencia máxima (Pmax)	545W
Cell efficiency / Eficiencia	21.09%
Max. power voltage / Voltaje a potencia max. (Vmp)	41.77V
Max. power current / Corriente a potencia max.	13.05A
Open circuit voltage / Voltaje en abierto (Voc)	49.6V
Short circuit current / Corriente de corto circuito (Isc)	13.93A
Power tolerance / Tolerancia de potencia	3%
Max. system voltage / Voltaje max. del sistema	1.500V
Max. Over Current / Sobre-Corriente Máxima	25A
Application Class	Class A

(\* Irradiance: 1000W/m<sup>2</sup> / AM1.5G, Module T: 25°C

### Temperature Characteristics

Nominal Operating Temperature / Temp. de operación (NMOT)	41 +/- 3°C
Operating range / Rango de operación	-40 to 85°C
Isc coefficient / Coeficiente (a I <sub>sc</sub> )	0.048%/°C
Voc coefficient / Coeficiente Temp (b Voc)	-0.29%/°C
Pmax coefficient / Coeficiente (g Pmax).	-0.36%/°C

### Connections

Junction Box / Caja de conexiones	IP68, 3 bypass diodes
Connectors / Conectores	(+) & (-) MC4 compatible
Cables	4mm <sup>2</sup> Solar Cable, L: 400mm (customizable)

### Physical Specifications

Dimensions / Tamaño	2278*1134*35mm
Weight / Peso	28Kg
Solar Cells Arrangement / Cantidad de celdas	144 : 2*(6*12)
Panel Construcción / Estructura del Panel	5 layers
Tempered Glass / Cristal Templado (EN 1096-4:2004)	High transmission, low-iron Solar Glass / Cristal Solar Anti reflectivo de bajo-hierro (3.2mm)
Backsheet / Laminado trasero (Toyol - TUV)	FPL High Reflectance Anti-UV long lifetime / FPL reflectante / Anti-UV / de larga vida (0.334mm)
EVA: Ethylene Vinyl Acetate (First - UL)	High light transmission + High UV Block / De alta transmisión de luz + alto bloqueo UV (0.45mm)
Solar Cells / Celdas solares (Taiwan # 1 Manufacturer)	"A" grade manufactured / Grado "A"
Junction Box / Caja de Conexión	IP68
Frame / Marco	High corrosion resistance anodized aluminium / Aluminio anodizado resistente a corrosión

### Packing

Carton: 2pcs / Pallet: 31pcs
FCL20: 10 pallets = 310pcs
FCL40: 20 pallets = 620pcs

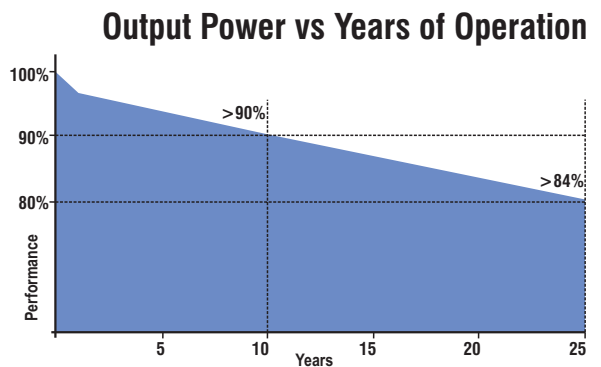
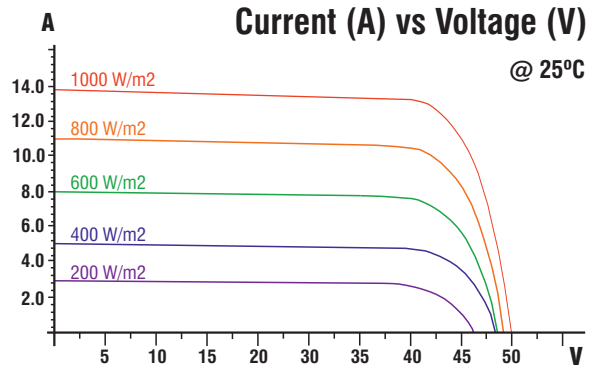
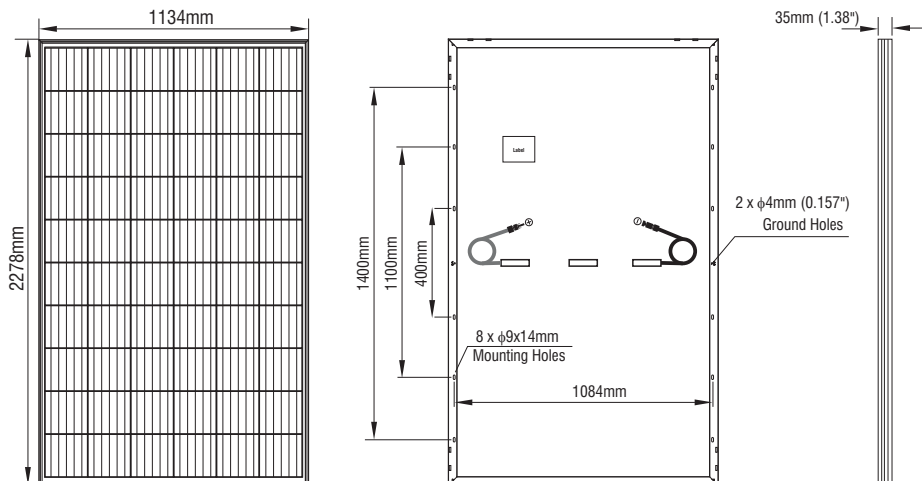

## XPV SOLAR PANEL

# XPV-FLEX-100W-20M

## Monocrystalline Flexible PV Solar Panel

### Flexible Solar Panel (ETFE)

Monocrystalline technology cells  
Panel with flexible, thin, and ultra-light structure  
Water and corrosion resistant  
High energy efficiency > 22%  
High performance under low light conditions  
Great resistance to severe environmental conditions  
Easy to install  
Ideal for installation on curved and/or mobile surfaces  
Made with high resistance and quality materials



**MONO**  
**100W**

**Monocrytall - Max. Power 100W (STC\*):**  
High-efficiency solar cells

**VMP**  
**20**

**Voltage at Max. Power**  
Vmp: 20.16V

**36**

**36 cells in series:**  
(4\*9) MONO (166\*83mm)

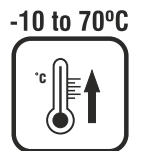
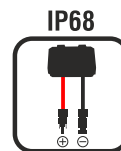

# XPV

Flexible Panels

**Technical Features / Características Técnicas** **XPV SOLAR PANEL**

# XPV-FLEX-100W-20M

## Electrical Specifications (STC\*)

Peak power / Potencia máxima (Pmax)	100W
Cell efficiency / Eficiencia	22.60%
Max. power voltage / Voltaje a potencia max. (Vmp)	20.16V
Max. power current / Corriente a potencia max.	4.96A
Open circuit voltage / Voltaje en abierto (Voc)	23.39V
Short circuit current / Corriente de corto circuito (Isc)	5.26A
Power tolerance / Tolerancia de potencia	3%
Max. system voltage / Voltaje max. del sistema	600VDC
Series fuse rating / Valor fusibles en serie	15A
Qty. bypass diodes / Cantidad de diodos de bypass	2 bypass diodes

(\* Irradiance: 1000W/m<sup>2</sup> / AM1.5, Cell T: 25°C

## Temperature Characteristics

Nominal Operating Temperature / Temp. de operación	42 +/- 2°C
Operating range / Rango de operación	-10 to +70°C
Temperature Coefficients of Isc	0.07%/°C
Temperature Coefficients of Voc	-0.36%/°C
Temperature Coefficients of Pmp	-0.38%/°C

## Connections

Junction Box / Caja de conexiones	IP68 (2 bypass diodes)
Connectors / Conectores	2 x MC4
Cables	2 x 50cm (+ & -)

## Physical Characteristics

Dimensions / Medidas	838*720*3mm
Weight / Peso	2.45Kg
Solar Cells Arrangement / Cantidad y tipo de celdas	36 in series (4*9) (MONO: 166*83mm)
Panel Construction / Laminación	5 layers
Top Layer / Layer Superior	ETFE
Backsheet / Laminado trasero	QPL High Reflectance Anti-UV long lifetime / QPL reflectante / Anti-UV / de larga vida
EVA: Ethylene Vinyl Acetate	High light transmission + High UV Block / De alta transmisión de luz + alto bloqueo UV
Max Wind Load / Snow Load (Pa)	2400 / 5400
Application Class	Class A
Fire Rating	Class C

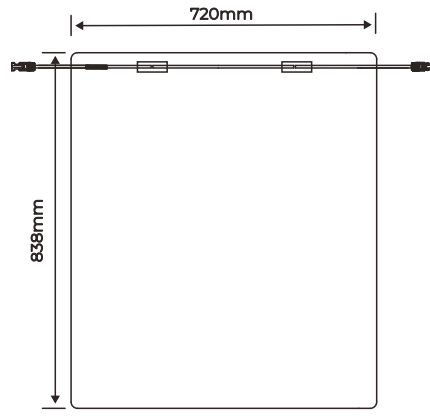
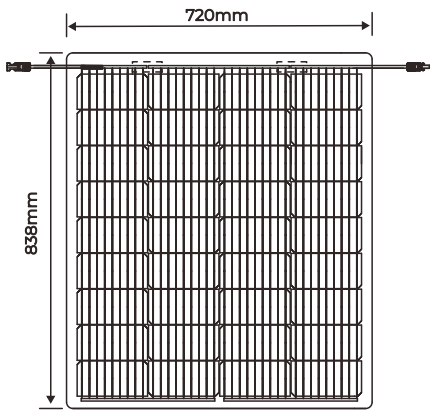
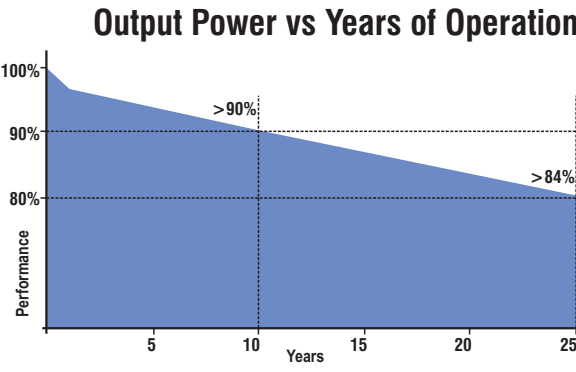
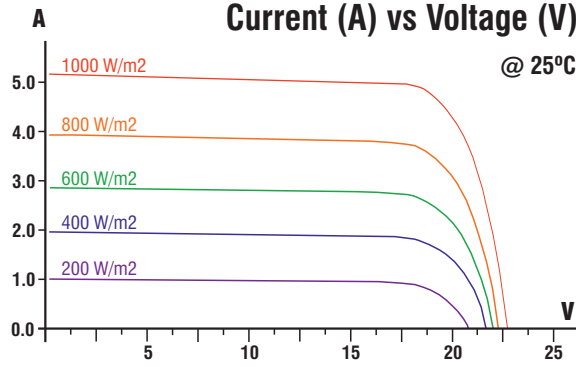

## XPV SOLAR PANEL

# XPV-FLEX-200W-20M

## Monocrystalline Flexible PV Solar Panel

### Flexible Solar Panel (ETFE)

Monocrystalline technology cells  
Panel with flexible, thin, and ultra-light structure  
Water and corrosion resistant  
High energy efficiency > 22%  
High performance under low light conditions  
Great resistance to severe environmental conditions  
Easy to install  
Ideal for installation on curved and/or mobile surfaces  
Made with high resistance and quality materials

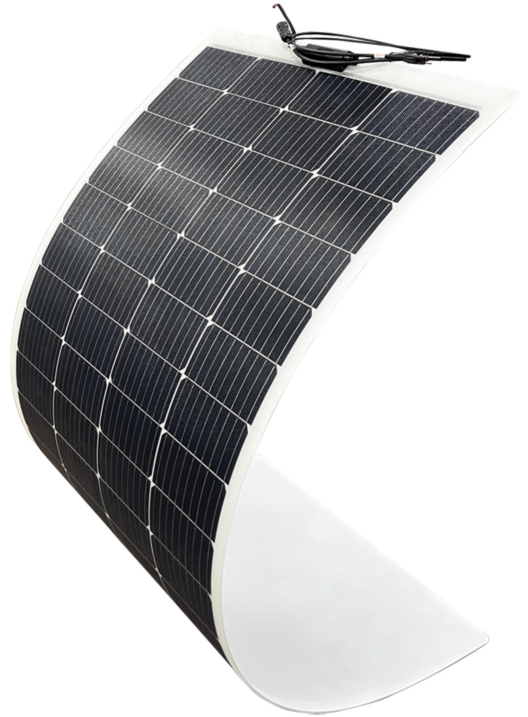

**MONO 200W** Monocrytall - Max. Power 200W (STC\*):  
High-efficiency solar cells

**VMP 20** Voltage at Max. Power  
Vmp: 20.16V

**72** 36 cells in series:  
(2\*2\*18) MONO (166\*83mm)

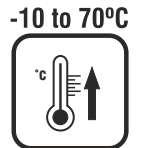
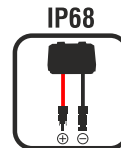

**Technical Features / Características Técnicas** **XPV SOLAR PANEL**

# XPV-FLEX-200W-20M

## Electrical Specifications (STC\*)

Peak power / Potencia máxima (Pmax)	200W
Cell efficiency / Eficiencia	22.6%
Max. power voltage / Voltaje a potencia max. (Vmp)	20.16V
Max. power current / Corriente a potencia max.	9.92A
Open circuit voltage / Voltaje en abierto (Voc)	24.3V
Short circuit current / Corriente de corto circuito (Isc)	10.5A
Power tolerance / Tolerancia de potencia	3%
Max. system voltage / Voltaje max. del sistema	600VDC
Series fuse rating / Valor fusibles en serie	15A
Qty. bypass diodes / Cantidad de diodos de bypass	2 bypass diodes

(\* Irradiance: 1000W/m<sup>2</sup> / AM1.5, Cell T: 25°C

## Temperature Characteristics

Nominal Operating Temperature / Temp. de operación	42 +/- 2°C
Operating range / Rango de operación	-10 to +70°C
Temperature Coefficients of Isc	0.07%/°C
Temperature Coefficients of Voc	-0.36%/°C
Temperature Coefficients of Pmp	-0.38%/°C

## Connections

Junction Box / Caja de conexiones	IP68
Connectors / Conectores	2 x MC4
Cables	2 x 50cm (+ & -)

## Physical Characteristics

Dimensions / Medidas	1595*720*3mm
Weight / Peso	4.45Kg
Solar Cells Arrangement / Cantidad y tipo de celdas	72 cells: 36 in series (2x2*18) (MONO: 166*83mm)
Panel Construction / Laminación	5 layers
Top Layer / Layer Superior	ETFE
Backsheet / Laminado trasero	QPL High Reflectance Anti-UV long lifetime / QPL reflectante / Anti-UV / de larga vida
EVA: Ethylene Vinyl Acetate	High light transmission + High UV Block / De alta transmisión de luz + alto bloqueo UV
Max Wind Load / Snow Load (Pa)	2400 / 5400
Application Class	Class A
Fire Rating	Class C

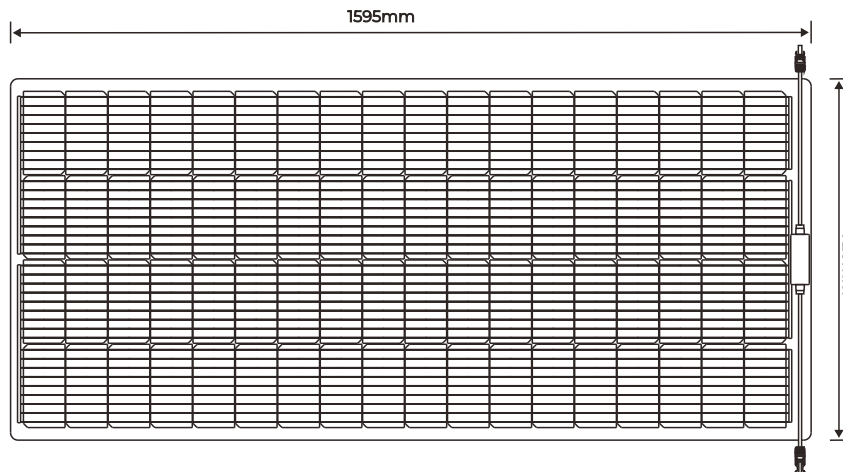
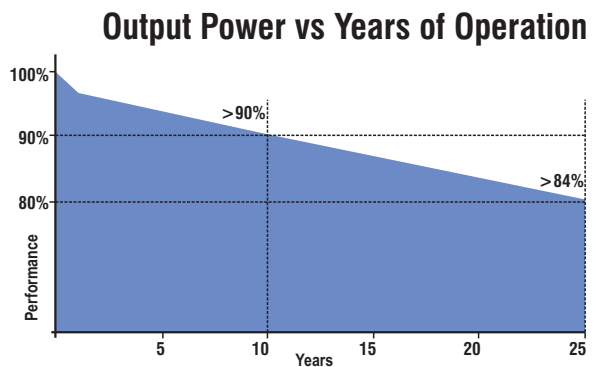
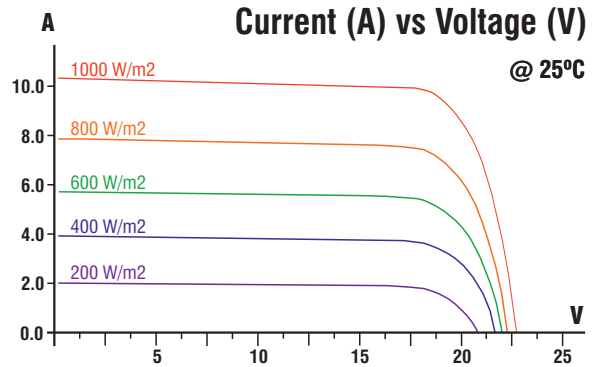

## XPV SOLAR PANEL

# XPV-FLEX-B-210W-40M

## Monocrystalline Flexible PV Solar Panel

### Flexible Solar Panel XPV Balcony

Monocrystalline technology cells  
Panel with flexible, thin, and ultra-light structure  
Ideal for installation on balconies and fences  
Water and corrosion resistant  
High energy efficiency > 22%  
High performance under low light conditions  
Great resistance to severe environmental conditions  
Easy to install

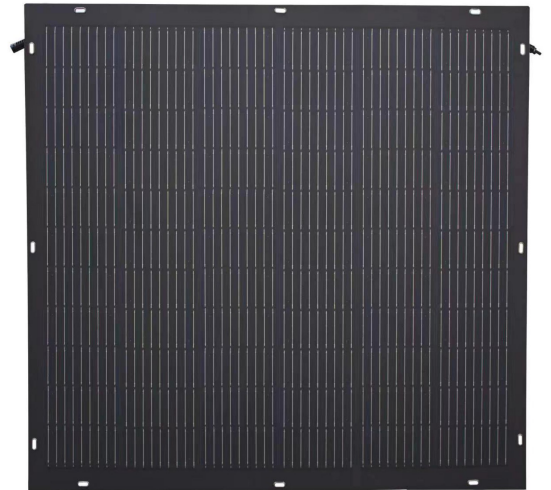

**Technical Features / Características Técnicas** **XPV SOLAR PANEL**

# XPV-FLEX-B-210W-40M

## Electrical Specifications (STC\*)

Peak power / Potencia máxima (Pmax)	210W
Cell efficiency / Eficiencia	22.30%
Max. power voltage / Voltaje a potencia max. (Vmp)	40.32V
Max. power current / Corriente a potencia max.	5.21A
Open circuit voltage / Voltaje en abierto (Voc)	48.6V
Short circuit current / Corriente de corto circuito (Isc)	5.52A
Power tolerance / Tolerancia de potencia	3%
Max. system voltage / Voltaje max. del sistema	600VDC
Series fuse rating / Valor fusibles en serie	15A
Qty. bypass diodes / Cantidad de diodos de bypass	2 bypass diodes

(\* Irradiance: 1000W/m<sup>2</sup> / AM1.5, Cell T: 25°C

## Temperature Characteristics

Nominal Operating Temperature / Temp. de operación	42 +/- 2°C
Operating range / Rango de operación	-10 to +70°C
Temperature Coefficients of Isc	0.046%/°C
Temperature Coefficients of Voc	-0.26%/°C
Temperature Coefficients of Pmp	-0.32%/°C

## Connections

Junction Box / Caja de conexiones	IP68
Connectors / Conectores	2 x MC4
Cables	2 x 40cm (+ & -)

## Physical Characteristics

Dimensions / Medidas	1085*1085*3mm
Weight / Peso	3.95Kg
Solar Cells Arrangement / Cantidad y tipo de celdas	72 cells: 72 in series (6*12) (MONO: 166*83mm)
Panel Construction / Laminación	5 layers
Top Layer / Layer Superior	PET
Backsheet / Laminado trasero	QPL High Reflectance Anti-UV long lifetime / QPL reflectante / Anti-UV / de larga vida
EVA: Ethylene Vinyl Acetate	High light transmission + High UV Block / De alta transmisión de luz + alto bloqueo UV
Max Wind Load / Snow Load (Pa)	2400 / 5400
Application Class	Class A
Fire Rating	Class C

**A** Current (A) vs Voltage (V) @ 25°C

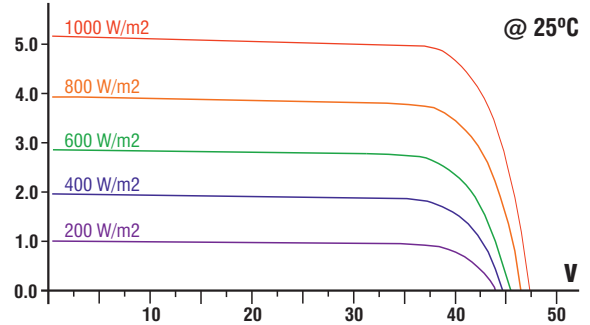

**B** Output Power vs Years of Operation

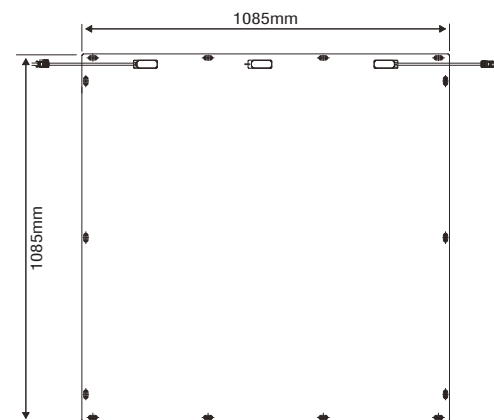
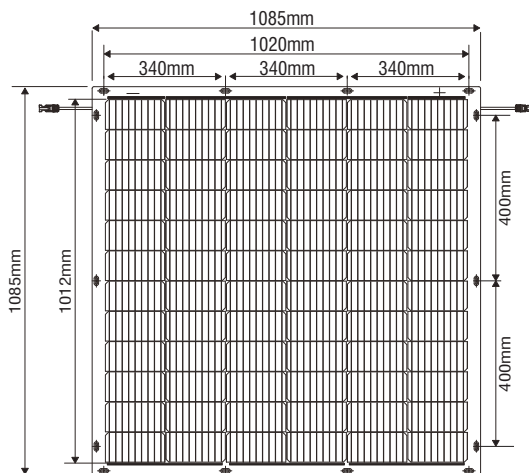
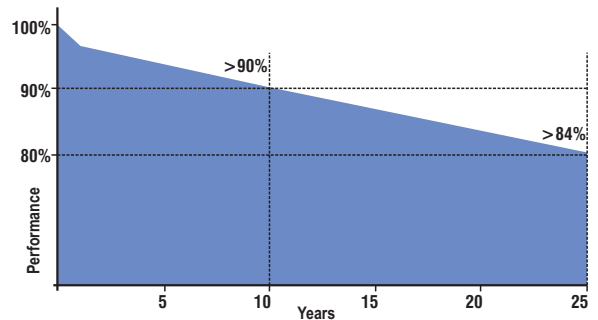

## XPV SOLAR PANEL

# XPV-FOLD-CHGR-36W

## Monocrystalline Flexible PV Solar Panel

### Foldable Solar Panel

Monocrystalline technology cells  
Panel with foldable, thin, and ultra-light structure  
High energy efficiency >21%  
High performance under low light conditions  
No installation required  
Ideal for camping and outdoors adventures, without losing connectivity or fun  
With USB Type-A & Type-C ports, more versatility and availability  
Made with high resistance and quality materials

**MONO**  
**36W**

Monocrystal - Potencia Máxima 36W (STC\*):  
Celdas solares de alta eficiencia

**VMP**  
**13**

Voltaje a Potencia Máxima  
Vmp: 13.40V

**24**



24 celdas en serie:  
(1\*3\*8) MONO

Product  
Warranty  
**2 Years**



**xpv**  
Flexible Panels

**Technical Features / Características Técnicas** **XPV SOLAR PANEL**

**XPV-FOLD-CHGR-36W**

**Electrical Specifications (STC\*)**

Peak power / Potencia máxima (Pmax)	36W
Efficiency / Eficiencia	21.30%
Max. power voltage / Voltaje a potencia max. (Vmp)	13.4V
Max. power current / Corriente a potencia max.	2.68A
Open circuit voltage / Voltaje en abierto (Voc)	16.15V
Short circuit current / Corriente de corto circuito (Isc)	2.84A
Power tolerance / Tolerancia de potencia	3%
Max. system voltage / Voltaje max. del sistema	600VDC

(\*) Irradiance: 1000W/m<sup>2</sup> / AM1.5, Cell T: 25°C

**Connections**

USB Type-A & Type-C Ports / Puertos USB tipo A & C	5V/2.4A, 9V/2A, 12V/1.5A
Cables	N/A

**Physical Characteristics**

Dimensions Unfolded / Medidas Desplegado	765*276*18mm
Dimensions Folded / Medidas Plegado	276*190*28mm
Weight / Peso	0.75Kg
Solar Cells Array / Cantidad y tipo de celdas	24 in series (1*3*8, MONO)

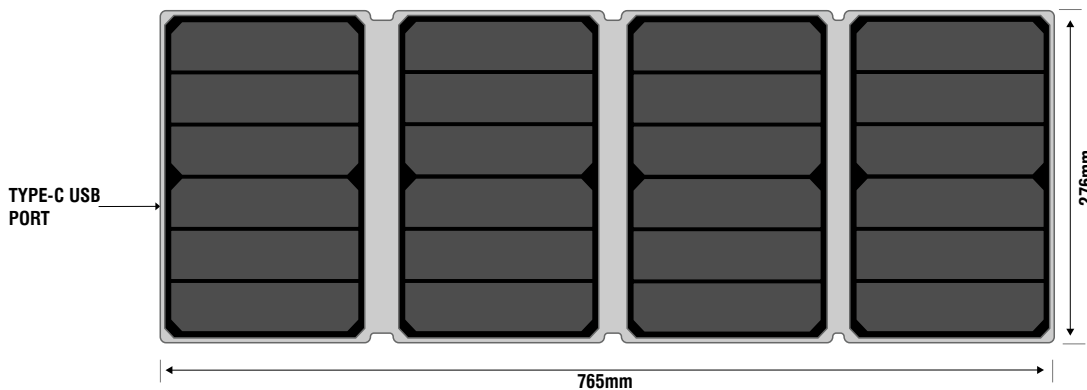
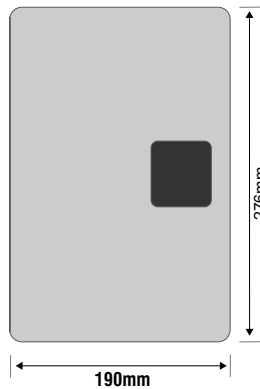
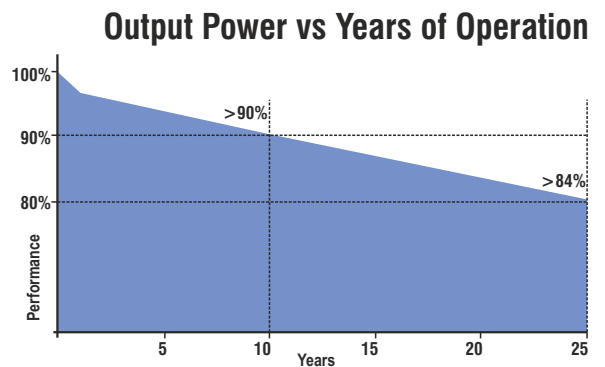
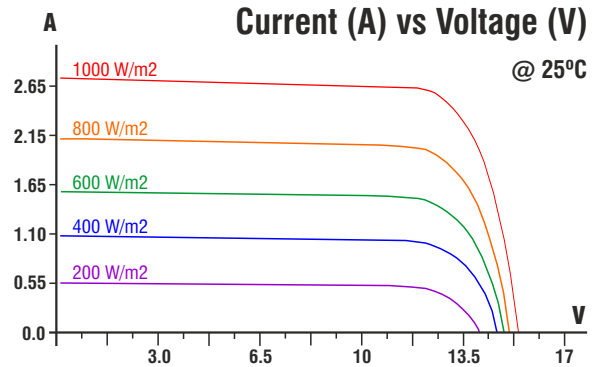

## XPV SOLAR PANEL

# XPV-FOLD-60W

## Monocrystalline Flexible PV Solar Panel

### Foldable Solar Panel

Monocrystalline technology cells  
Panel with foldable, thin, and ultra-light structure  
High energy efficiency > 22%  
High performance under low light conditions  
No installation required  
Ideal for camping and outdoors adventures, without losing connectivity or fun.  
Made with high resistance and quality materials



**MONO 60W** Monocrystal - Potencia Máxima 60W (STC\*):  
Celdas solares de alta eficiencia

**VMP 23** Voltaje a Potencia Máxima  
Vmp: 23.52V

**42** 42 celdas en serie:  
(3\*7\*2) MONO

Product  
Warranty  
**2 Years**



**xpv**  
Foldable Panels

**Technical Features / Características Técnicas** **XPV SOLAR PANEL**

**XPV-FOLD-CHGR-36W**

**Electrical Specifications (STC\*)**

Peak power / Potencia máxima (Pmax)	60W
Efficiency / Eficiencia	22.60%
Max. power voltage / Voltaje a potencia max. (Vmp)	23.52V
Max. power current / Corriente a potencia max.	2.55A
Open circuit voltage / Voltaje en abierto (Voc)	28.30V
Short circuit current / Corriente de corto circuito (Isc)	2.71A
Power tolerance / Tolerancia de potencia	3%
Max. system voltage / Voltaje max. del sistema	600VDC
(*) Irradiance: 1000W/m2 / AM1.5, Cell T: 25°C	

**Connections**

Connector / Conector	Anderson / DC7909
Cable	1 mt

**Physical Characteristics**

Dimensions Unfolded / Medidas Desplegado	1220*555*25mm
Dimensions Folded / Medidas Plegado	610*555*45mm
Weight / Peso	3.5Kg
Solar Cells Array / Cantidad y tipo de celdas	42 in series (3*7*2, MONO)

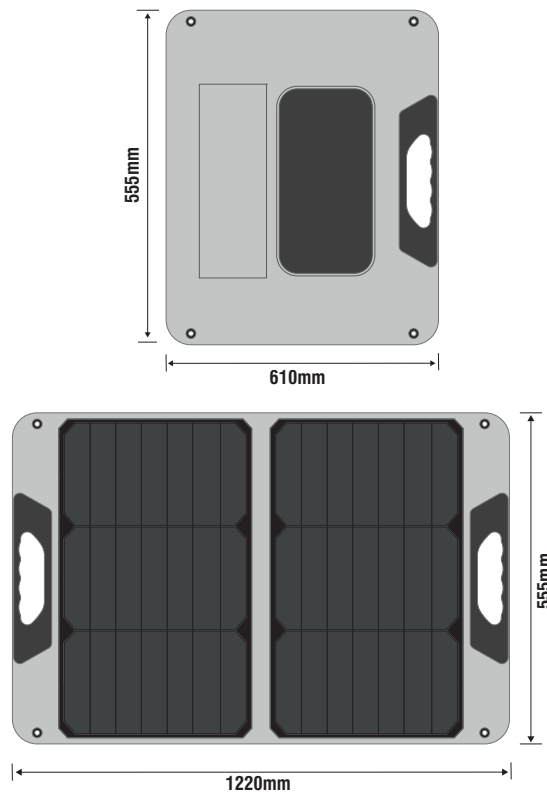
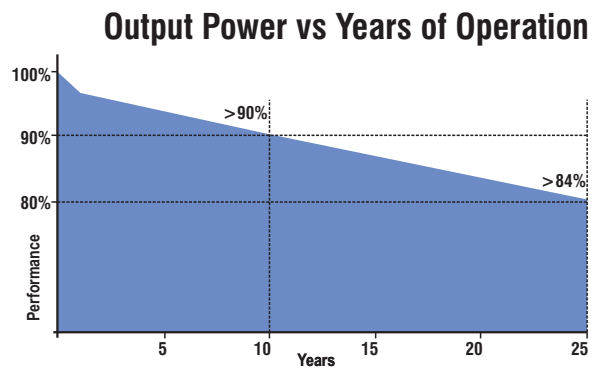
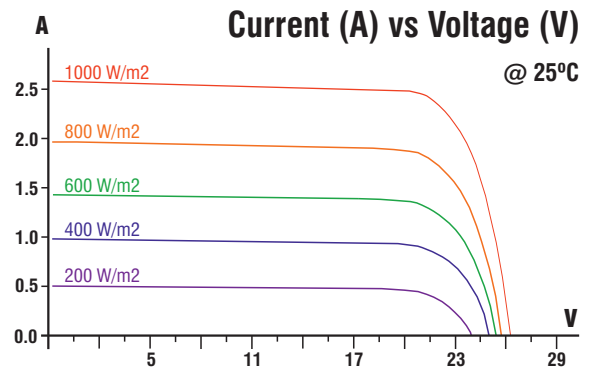

## XPV SOLAR PANEL

# XPV-FOLD-100W

## Monocrystalline Foldable PV Solar Panel

### Foldable Solar Panel

Monocrystalline technology cells  
Panel with foldable, thin, and ultra-light structure  
High energy efficiency > 22%  
High performance under low light conditions  
No installation required  
Ideal for camping and outdoors adventures, without losing connectivity or fun.  
Made with high resistance and quality materials

**MONO**  
**100W**

**Monocrystal - Potencia Máxima 100W (STC\*):**  
Celdas solares de alta eficiencia

**VMP**  
**20**

**Voltaje a Potencia Máxima**  
Vmp: 20.16V

**36**



**36 celdas en serie:**  
(3\*6\*2) MONO

**Product**  
**Warranty**

**2 Years**



**xpv**

**Foldable Panels**

**Technical Features / Características Técnicas** **XPV SOLAR PANEL**

**XPV-FOLD-100W**

**Electrical Specifications (STC\*)**

Peak power / Potencia máxima (Pmax)	100W
Efficiency / Eficiencia	21.30%
Max. power voltage / Voltaje a potencia max. (Vmp)	20.16V
Max. power current / Corriente a potencia max.	4.96A
Open circuit voltage / Voltaje en abierto (Voc)	24.30V
Short circuit current / Corriente de corto circuito (Isc)	5.25A
Power tolerance / Tolerancia de potencia	3%
Max. system voltage / Voltaje max. del sistema	600VDC

(\*) Irradiance: 1000W/m<sup>2</sup> / AM1.5, Cell T: 25°C

**Connections**

Connector / Conector	Anderson / DC7909
Cable	1.5 mt

**Physical Characteristics**

Dimensions Unfolded / Medidas Desplegado	1220*555*25mm
Dimensions Folded / Medidas Plegado	610*555*45mm
Weight / Peso	4.8Kg
Solar Cells Array / Cantidad y tipo de celdas	36 in series (3*6*2, MONO)

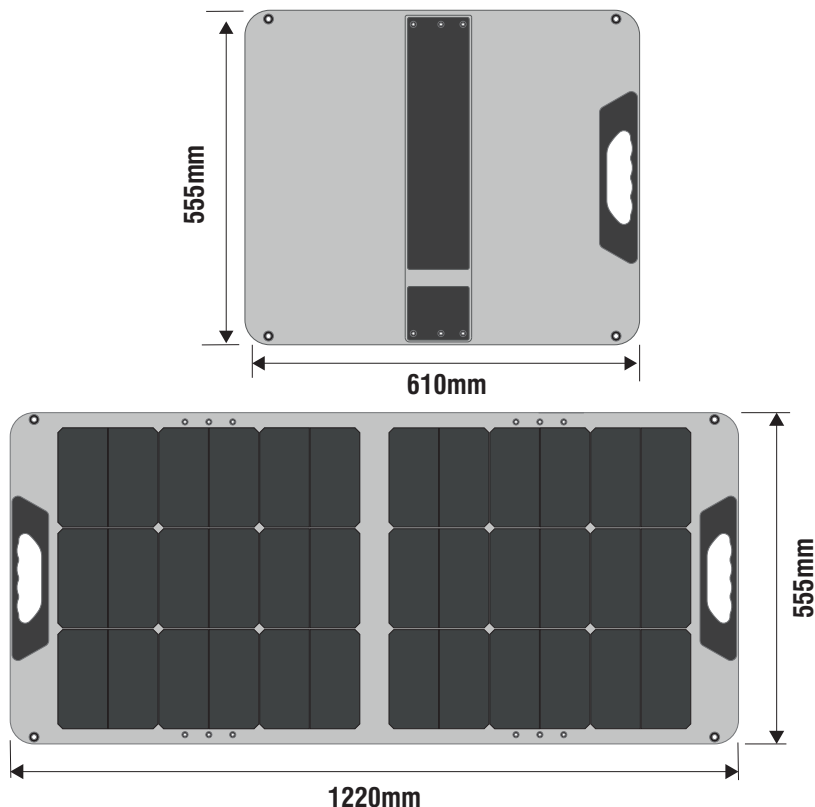
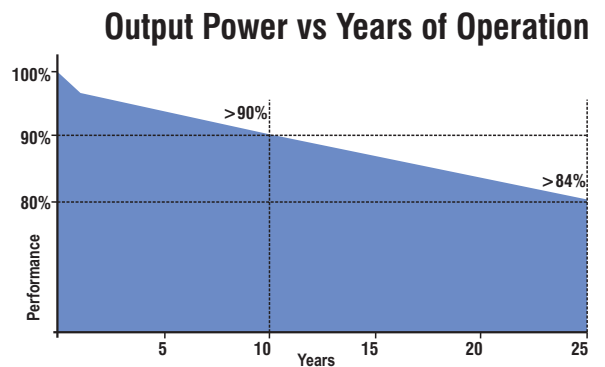
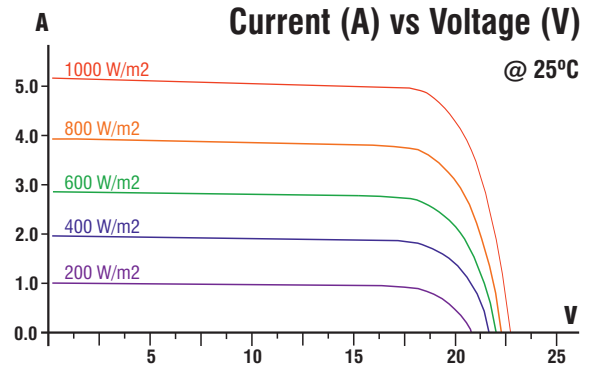

## XPV SOLAR PANEL

# XPV-FOLD-200W

## Monocrystalline Foldable PV Solar Panel

### Foldable Solar Panel

Monocrystalline technology cells  
Panel with foldable, thin, and ultra-light structure  
High energy efficiency > 22%  
High performance under low light conditions  
No installation required  
Ideal for camping and outdoors adventures, without losing connectivity or fun.  
Made with high resistance and quality materials

**MONO**  
**200W**

Monocrystal - Potencia Máxima 100W (STC\*):  
Celdas solares de alta eficiencia

**VMP**  
**20**

Voltaje a Potencia Máxima  
Vmp: 20.16V

**72**



72celdas en serie:  
(3\*6\*4) MONO

Product  
Warranty

**2 Years**



# XPV

Foldable Panels

**Technical Features / Características Técnicas** **XPV SOLAR PANEL**

**XPV-FOLD-100W**

**Electrical Specifications (STC\*)**

Peak power / Potencia máxima (Pmax)	200W
Efficiency / Eficiencia	21.30%
Max. power voltage / Voltaje a potencia max. (Vmp)	20.16V
Max. power current / Corriente a potencia max.	9.92A
Open circuit voltage / Voltaje en abierto (Voc)	24.30V
Short circuit current / Corriente de corto circuito (Isc)	10.50A
Power tolerance / Tolerancia de potencia	3%
Max. system voltage / Voltaje max. del sistema	600VDC
(*) Irradiance: 1000W/m <sup>2</sup> / AM1.5, Cell T: 25°C	

**Connections**

Connector / Conector	Anderson / DC7909
Cable	1.5 mt

**Physical Characteristics**

Dimensions Unfolded / Medidas Desplegado	2365*535*25mm
Dimensions Folded / Medidas Plegado	626*535*50mm
Weight / Peso	8.6Kg
Solar Cells Array / Cantidad y tipo de celdas	72 in series (3*6*4, MONO)

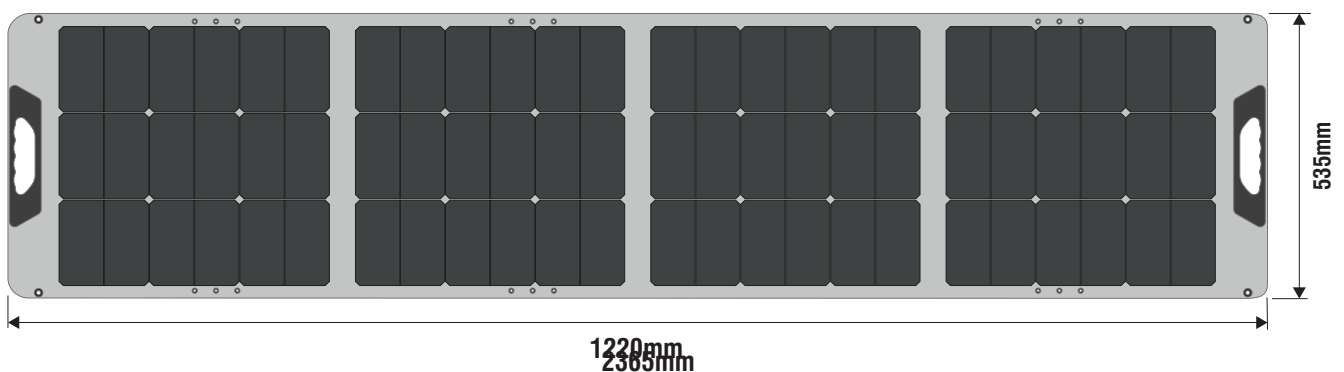
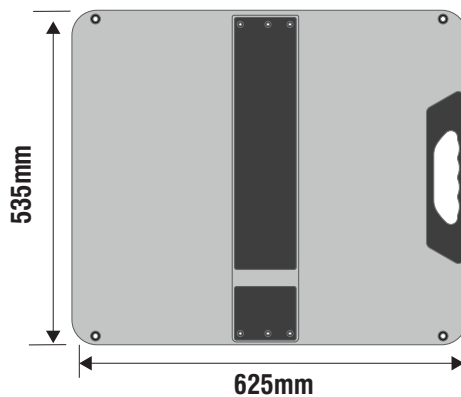
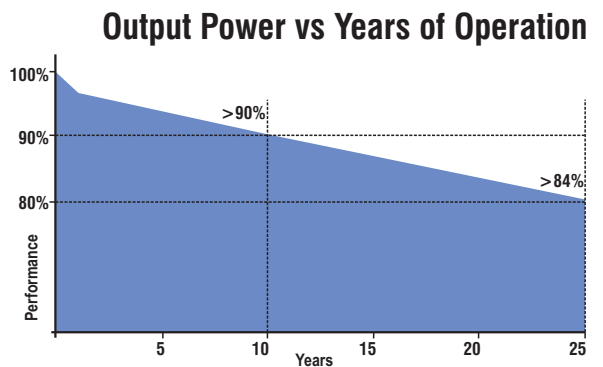
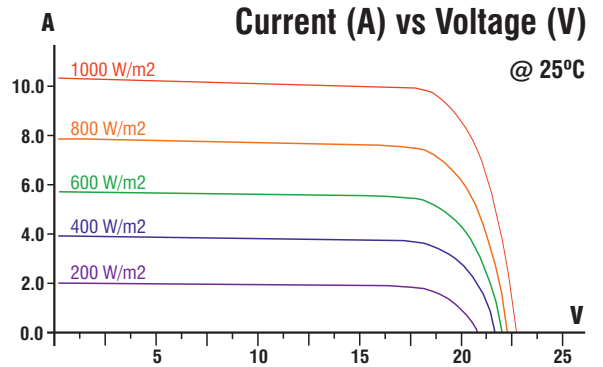

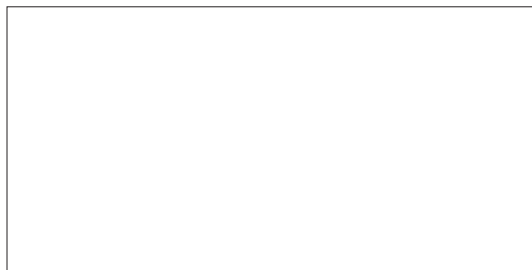

[www.xmart-ups.com](http://www.xmart-ups.com)